



Chemisch Beständige Radialventilatoren
Chemical Resistant Centrifugal Plastic Fan

R04.4



Symbole und Formelzeichen

Symbols and technical formula symbols



Symbol	Bedeutung / Meaning	Symbol	Bedeutung / Meaning	Symbol	Bedeutung / Meaning
	5-Stufen-Steuergerät, transformatorisch 5-step transformer control		Drehzahlumschalter Speed control switch		Schaltplan Wiring diagram
	Steuergerät, stufenlos, transformatorisch Continuously adjustable transformer control		Geräteausschalter Off-Switch		explosionsgeschützt flame proof
	Steuergerät, stufenlos, elektronisch Continuously adjustable electronic control		Gewicht Weight		Abmessungen Dimensions
	Motorschutzschalter Motor protection switch		Schutzart Protection class		Zubehör Accessories

Größe Symbol	Benennung	Designation	Einheit Unit
A	Querschnittsfläche	Cross-section	m ²
c	Strömungsgeschwindigkeit	Flow speed	m/s
C _{400V}	Betriebskondensator	Capacitor	µF
D ₂	Durchmesser des Laufrades	Impeller diameter	m
d	Rohrdurchmesser	Pipe diameter	m
d _g	gleichwertiger Durchmesser	Equivalent diameter	m
Freq	Spannungssteller	Frequency Invertor Speed Controller	-
g	Fallbeschleunigung	Gravitational speed acceleration	m/s ²
I _N	Nennstrom	Rated current	A
I _A / I _N	Verhältnis Anlaufstrom zu Nennstrom	Ratio of starting current to rated current	
Δ I	Stromanstieg bei Teilspannung	Current increase in component voltage area	%
l	Rohr- bzw. Kanallänge	Pipe or channel length	m
L _{PA}	A-bewerteter Schalldruckpegel	Sound pressure level A-weighted	dB(A)
L _{WA}	A-bewerteter Schalleistungspegel	Sound power level A-weighted at inlet	dB(A)
L _{WA2}	Schalleistungspegel zur Umgebung	Sound power level to surrounding	dB(A)
L _{WA3}	Ansaugkanalschalleistungspegel	Inlet sound power level induct	dB(A)
L _{WA4}	Ausblaskanalschalleistungspegel	Outlet sound power level induct	dB(A)
L _{WA5}	Freiansaug-Schalleistungspegel	Inlet sound power level unducted	dB(A)
L _{WA6}	Freiausblas-Schalleistungspegel	Outlet sound power level unducted	dB(A)
n	Drehzahl	Speed	1/min (bzw. 1/s)
P ₁	Motoraufnahmeleistung	motor power consumption	kW (bzw. W)
p _{st} (p _{fa})	statischer Druck	Static pressure	Pa
Δ p _{st}	Differenz der statischen Drücke	Differential static pressure	Pa
Δ p _{fa min}	erforderlicher statischer Mindestgegendruck	min. required counter pressure	Pa
p _d	dynamischer Druck	Dynamic pressure	Pa
p _{d2}	dynamischer Druck am Ventilatoraustritt	Dynamic pressure at fan outlet	Pa
Δ p _d	Differenz der statischen Drücke	Differential dynamic pressure	Pa
p _t	Gesamtdruck	Total pressure	Pa
Δ p _t	Differenz der Gesamtdrücke	Difference of total pressures	Pa
T	Kelvin-Temperatur	Temperature in Kelvin	K
t	Celsius-Temperatur	Temperature in Celsius	°C
t _R	max. zulässige Fördertemperatur	max. permissable medium temperature	°C
u ₂	Umfangsgeschwindigkeit des Laufrades (außen)	Circumferential speed of the impeller (outside)	m/s
Ṁ	Volumenstrom	Volume flow	m ³ /h (bzw. m ³ /s)
ρ	Dichte des Fördermediums	Density of medium	kg/m ³
η	Wirkungsgrad	Efficiency	-
φ	Volumenzahl	Volume number	-
ψ	Druckzahl	Pressure number	-
ζ	Widerstandsbeiwert	Coefficient of drag	-
λR	Rohr- bzw. Kanalreibungsbeiwert	Coefficient of friction of channel or pipe	-

Inhaltsverzeichnis	Contents	1
Technische Informationen	Technical information	2-5
Ventilatorcurven	Fan curves	6-26
Schallangaben	Sound information	27-28
Abmessungen	Dimensions	29-37
Auf-und Einbau	Assembly and mounting	38-44
Ausschreibungstexte	Specification	45-50

CHEMCO chemisch widerstandsfähige Kunststoff-Lüfter

CHEMCO = chemical resistant plastic fan

Rolle

Chemco spielte eine führende Rolle bei der Herstellung von Gegenständen aus nicht rostenden und chemisch widerstandsfähigen Kunststoffen. Diese Geräte sind bestens geeignet für Belüftungs- & Lärmbekämpfungssysteme, Reinraumtechnik, Galvanisier-Anlagen, Laboratoriums-Abflüsse & Behälter, Bürsten, Wasserspeicher und kundenspezifische Systeme.

Erfahrung

Aufgrund der langjährigen Erfahrung und Know-How im Kunststoffbereich, war es Chemco möglich eine komplette Baureihe von nicht rostenden Ventilatoren zu entwickeln. Die Ventilatoren zeichnen sich durch einen hohen Wirkungsgrad, zuverlässiges Betriebsverhalten und hervorragende Korrosionsfestigkeit aus. Grundmerkmale sind ebenso die einfache Wartung und die Wirtschaftlichkeit.

Anwendung

Chemco korrosionsbeständige Kunststoff-Ventilatoren sind speziell entwickelt um schwerkorrosive Rauchgase, Dämpfe, verseuchte Luft und aggressive Gase zu handhaben. Solche Ventilatoren eignen sich zum Gebrauch im Prüflabor, Krankenhaus, Nahrungsmittelindustrie, Elektronikindustrie, chemisch und galvanische Metallbeschichtungs-Gewerbe, Reinraumtechnik usw. oder auch für die Luftaufbereitung in der Bauindustrie.

Gütegrad

Chemco bietet eine komplette Baureihe wirkungsvoller rückwärtsgekrümmter Radialventilatoren hoher Qualität mit sehr guter Leistung und niedrigem Geräuschpegel. Alle Ventilator-Antriebe und Zubehörteile werden nach genauen Qualitätsstufen hergestellt. Es kommen nur Qualitäts-Werkstoffe zum Einsatz und alle Ventilatoren sind erprobt und geprüft nach DIN 24163, ISO 5801 und AMCA 210.

Erzeugnisse und Leistung

Chemco Radial-Ventilatoren und Dachventilatoren mit horizontalem oder senkrechtem Ausblas bieten Leistungen von bis zu 180.000 m³/h und statischem Druck von bis zu 7.000 Pa.

Thermoplastische Kunststoffe wie PP, PE, PVC, PVDF oder GFK die Widerstandsfähigkeit gegen die meisten Chemikalien bieten sind verfügbar.

Schallpegel

Um eine Bewertung entsprechend dem menschlichen Gehör zu ermöglichen wurde die A-bewertete Beschreibung des Schallpegels gemäß DIN 45635 gewählt.

Die Schallmessung erfolgt mit dem Hüllflächenverfahren gemäß DIN 45635 Teil 38 oder dem Kanalverfahren DIN 45635 Teil 9 oder AMCA 300.

CHEMCO CHEMICAL RESISTANT PLASTIC FAN

CHEMCO = chemical resistant plastic fan

Role

Chemco has played a leading role in the manufacturing of equipment made from anti-corrosive and chemical resistant plastics. These equipment are most suitable for use in the ventilation & noise control systems, clean rooms engineering, plating equipment, laboratory sinks & containers, scrubbers, tank constructions as well as custom design systems.

Experience

The years of experience and know-how in the areas of plastics, its designing capability enables Chemco to develop a complete range of anticorrosive fans. The fans are specially designed for high efficiency, reliability, with superior corrosion resistance quality. They are also developed to give trouble-free service, and are economical in use.

Application

Chemco corrosive resistant plastic fans are specially developed to handle heavy corrosive fumes, vapours, contaminated air and aggressive gases. Such fans are suitable for use in the test laboratory, hospital, food industry, electronic industry, chemical and electroplating industry, clean rooms engineering etc. They are also suitable for air conditioning application in the building industry.

Quality

Chemco supply a complete range of highly quality and efficient radial tip backward curve fans, which offer an excellent performance with a low noise level. All fans drive and accessories are produced to strict quality standards. Only the best quality materials are used and all fans are tested and rated in accordance with DIN 24163, ISO 5801 and AMCA 210.

Products and Performance

Chemco centrifugal fans and roof fans with horizontal or vertical outlet have performance capacity of up to 180,000 cmh and operating at a static pressure of up to 7,000 Pa.

Thermoplastic materials such as PP, PE, PVC, PVDF or GRP that offer the best guarantee to resist most chemicals are available.

Sound Level

In order to make possible an assessment of sound projection adequate to human ear the A-assessed description of sound level according to DIN 45635 has been chosen.

The ascertaining of the sound power level follows the enveloping surfaces method according to DIN 45635 section 38, section 9 or AMCA 300.

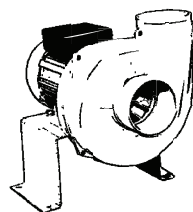

CHEM 75 - 110

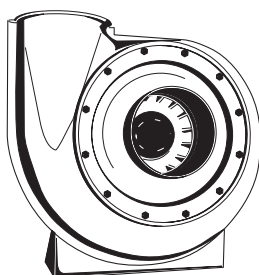

CHEM 125 - 200



Dongguan Wolter Chemco Ventilation Ltd. certifies that the series CHEM shown herein are licensed to bear the AMCA Seal. The ratings shown are based on tests and procedures performed in accordance with AMCA Publication 211 and AMCA Publication 311 and comply with the requirements of the AMCA Certified Ratings Program.

CHEM 75R to 180 are not licensed to bear the AMCA certified Ratings Seal.

The AMCA Certified Ratings Seal applies to air and sound performance for Model CHEM 200 to CHEM 1250.

Standardbaureihen und Ausführungen

Typ CHEM 75-315 DD

- mit Direktantrieb
- Kunststoff Spritzgußgehäuse standardmäßig aus PP
- CHEM 125 to 200 gehäuse passend für beide Drehrichtungen, montiert auf verzinktem Stahl-Bock, mit angeflanschem Normmotor
- Laufrad fliegend auf Motorwelle montiert
- Ventilator-Bock mit Stützwinkeln

Standard Models and Designs

Model CHEM 75 DD to 315 DD

- With direct drive
- Plastic injection moulded casing with PP as standard.
- CHEM 125 to 200 casing suitable for dual rotations mounted on the galvanised steel support comes with flanged standard motor
- Impeller mounted overhung on the motor shaft.
- Fan base with angle support

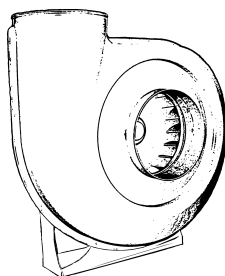

CHEM 250 - 315

Typ CHEM 125-315 BD

- mit Riemenantrieb
- Kunststoff Spritzgußgehäuse standardmäßig aus PP.
- CHEM 125 to 200 gehäuse passend für beide Drehrichtungen. Gehäuse passend für beide Drehrichtungen, montiert auf verzinktem Stahl-Bock, Doppel-Flanschlager aus Gußaluminium
- Laufrad fliegend auf Welle montiert
- Ventilator-Bock mit Kanal-Lagerung und Motor-montageplatte.

Model CHEM 125 BD to 315 BD

- With belt drive.
- Plastic injection moulded casing with PP as standard.
- CHEM 125 to 200 casing suitable for dual rotations. Casings are mounted on the galvanised steel support come with aluminium cast flanged-on twin bearing housing.
- Impeller fixed overhung on the shaft.
- Fan base with channel support include motor mounting plate.

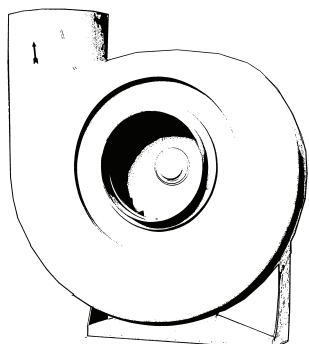

CHEM 400

Typ CHEM 400 DD

- mit Direktantrieb
- Glasfaserverstärkt (GFK/FFK)
- Gehäuse mit angeflanschem Normmotor, montiert auf verzinktem Stahl-Bock
- Laufrad fliegend auf Motorwelle montiert
- Ventilator-Bock mit Stützwinkeln

Model CHEM 400 DD

- With direct drive
- Glass-Reinforced Plastic (GRP/FRP) casing
- Casing mounted on the galvanised steel support comes with flanged standard motor.
- Impeller mounted overhung on the motor shaft.
- Fan base with angle support

Typ CHEM 400 BD

- mit Riemenantrieb.
- Glasfaserverstärkt (GFK/FFK)
- Gehäuse montiert auf verzinktem Stahl-Bock, Doppel-Flanschlager aus Gußaluminium
- Laufrad fliegend auf Welle montiert
- Ventilator-Bock mit Kanal-Lagerung und Motor-montageplatte

Model CHEM 400 BD

- With belt drive.
- Glass-Reinforced Plastic (GRP/FRP) casing
- Casing mounted on galvanised steel support comes with aluminium cast flanged-on twin bearing housing.
- Impeller fixed overhung on the shaft.
- Fan base with channel support include motor mounting plate

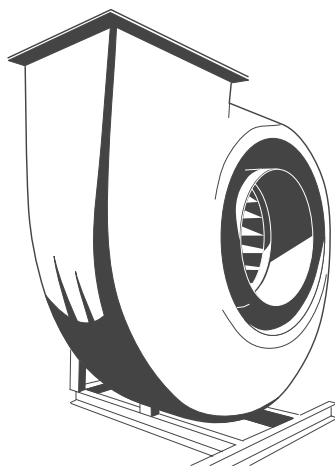

CHEM 450 - 710

Typ CHEM 450-710 DD

- mit Direktantrieb.
- Gehäuse als maschinell geschweißte Kunststoff-Konstruktion oder aus glasfaserverstärktem Kunststoff (GFK/FFK)
- Gehäuse an verzinktem Lagerbock montiert, mit Norm-Fußmotor
- Laufrad fliegend auf Motorwelle montiert
- Ventilator-Bock mit Kanal-Lagerung

Model CHEM 450 DD to 710 DD

- With direct drive.
- Casing in plastic mechanically welded construction or Glass-Reinforced Plastic (GRP/FRP)
- Casing mounted on galvanised steel support come with foot mounted standard motor.
- Impeller mounted overhung on the motor shaft.
- Fan base with channel support

Typ CHEM 450-1250 BD

- mit Riemenantrieb.
- Gehäuse als maschinell geschweißte Kunststoff-Konstruktion oder aus glasfaserverstärktem Kunststoff (GFK/FFK)
- Gehäuse an verzinktem Lagerbock montiert, Welle mit Pendelkugel-Stehlager
- Laufrad fliegend auf Welle montiert
- Ventilator-Bock mit Kanal-Lagerung und Motor-montageplatte

Model CHEM 450 BD to 1250 BD

- With belt drive.
- Casing in plastic mechanically welded construction or Glass-Reinforced Plastic (GRP/FRP)
- Casing mounted on galvanised steel support frame come with "pedestal" mounted self-aligning ball bearing units.
- Impeller fixed overhung on shaft.
- Fan base with channel support include motor mounting plate

Bei allen CHEM ist das Laufrad standardmäßig aus PP oder GFK G1 und G3. Das CHEM 400-1250 Ventilatorgehäuse gewöhnlich aus GFK/FFK, bietet gute Säure- und Laugenfestigkeit. Es kann ebenso mit Einlagen vermischt werden um Anforderungen an Hochtemperatur-, UV-Beständigkeit oder Schutz vor elektrostatischer Entladung zu genügen. Je nach Kundenwunsch.

All CHEM impeller come with PP as standard, GRP G1 and G3 as optional. CHEM 400 to 1250 fan casing usually of GRP/FRP material, good for chemical resistance, can also be blended with composites to withstand high temperature, flame retardant, UV or Electrostatic Discharge protection to suit customer's requirements.

Standard Farben

sämtliche PP - entsprechend PANTONE warm grau 1C,

sämtliche GFK - entsprechend PANTONE 430
Andere Farben wenn erforderliche.

Standard Colour

All PP - Equivalent to PANTONE Warm Grey 1C,

All GRP - Equivalent to PANTONE 430
Other colours as optional requirement.

Sicherheitstechnische Besonderheiten

Sämtliche Riementriebe, Scheiben, vorstehend Stellschrauben, Keile und andere rotierende Teile haben Verkleidungen aus strapazierfähigem perforiertem Blech, um sicherheitstechnische Forderungen zu erfüllen. Jeder Ventilator hat ein festmontiertes Typenschild mit Seriennummer und Modellbezeichnung, Lüfter + Antriebsdaten, Luftmenge und Fabrikationsdatum.

Safety Features

All drive-belts, pulleys, projecting set screws, keys and other rotating parts have heavy-duty perforated sheet as protective guards to meet safety requirements. All fans are labelled with nameplate securely attached on each fan showing the serial and model number, fan & drive duties, rotation of flow and date of manufacture.

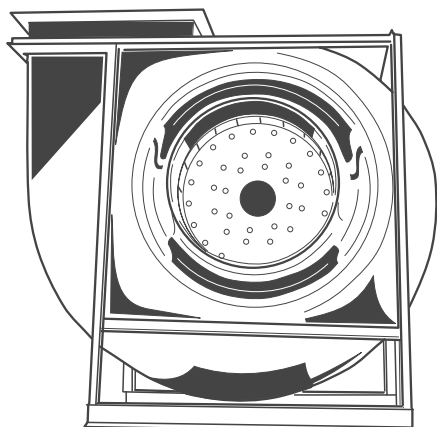

CHEM 800 -1250

Konstruktion der chemisch beständigen Radiallüfter

Gehäuse

Das Ventilatorgehäuse ist entweder aus thermoplastischen Kunststoffen wie PP, PVC, PE, PVDF oder Glasfaserverstärkten Kunststoffen - Vinyl Ester Klasse (GFK oder FFK). Das Ventilatorgehäuse hat die Form einer echten Spirale und hat eine Hochleistungsansaugdüse um eine gleichmäßige Luft-Verteilung über die volle Laufradbreite zu erreichen.

Die kleineren Gehäuse, Typ **CHEM 75 - 315** sind vollständig aus Spritz-Kunststoff. **CHEM 125 - 200** sind in jeder Position geeignet für doppel-dreh kann der Kunststoff-Spritzgussplatte oder Einlassabdeckung leicht zum Ändern der Dreh-, Wartung und Services entfernt werden. Gehäuse mit gerade Auslauf für die direkte Verbindung zum flexiblen Verbindungen kommen. Standardmaterial des Gehäuse ist PP.

Die **CHEM 400** Gehäuse sind gewöhnlich aus GFK oder vacuumgeformt und maschinell geschweißt. Die Rückscheibe und Ansaugdüse, beide aus Spritzkunststoff, können für Wartungsarbeiten leicht entfernt werden. Die GFK Ventilatorgehäuse haben einen runden geraden Ausblas passend zur direkten Montage eines elastischen Verbinders.

Die Gehäuse der größeren Ventilator-Baureihen (Typen **CHEM 450 - 1250**) sind standardmäßig aus GFK oder, wenn erforderlich, maschinell geschweißt.

Das Chemco Ventilatorgehäuse ist äußerst starr, mit angemessener Dicke, speziell versteift, um Schwingungen oder Poltern während des Betriebes auszuschließen. Um das Risiko der Korrosion zu verringern ist das Gehäuse so gebaut, dass sich keine Metallteile im Luftstrom befinden. Die Gehäuse können aus GFK oder einem thermoplastischen Material vermengt mit Füllstoffen sein um Anforderungen an Hochtemperatur-, UV-Beständigkeit oder Schutz vor elektrostatischer Entladung zu genügen. Je nach Kundenwunsch.

Der Ansaug und Ausblas haben Standard-Durchmesser, welche während der Montage leicht mit passenden elastischen Verbindern angeschlossen werden können.

Alle Gehäuse können am tiefsten Punkt der Spirale mit einem Kondensatablaufstutzen versehen werden. Dies erleichtert die Entwässerung von Kondensat bei Aufstellung im Freien.

Rückwärtsgekrümmte Radiallaufräder

Chemco Lüfterlaufräder sind einflutrig mit konstanter Breite (SISW). Die Herstellung erfolgt durch Präzisions-spritzguß mit eingegossener Metallnabe (Typen **CHEM 125 - 315**) oder maschinell geschweißt (Typen **CHEM 400 - 1250**). Sie entsprechen höchsten Qualitätsstufen und haben ausgezeichnete aerodynamische Eigenschaften.

Als Standard wird PP für das Laufrad verwendet, je nach Einsatzfall können auch PA, PC, PVC oder PVDF Verwendung finden. Entsprechend den Anforderungen des Kunden an Hochtemperatur-, UV-Beständigkeit oder Schutz vor elektrostatischer Entladung können die Laufräder auch aus einem thermoplastischen Material vermengt mit Füllstoffen sein. Jedes Laufrad ist, nach Q2,5 (VDI 2060) oder Gütegrad G2,5 (BS 5625 Teil 1 (1979)), statisch und dynamisch in zwei Ebenen gewuchtet. Die Radnaben sind für die Verwendung von Taper-lock-Naben vorgesehen und sind aus hochwertigen Gußplatten. Dies gewährleistet einen zuverlässigen Lauf auch bei hoher Umfangsgeschwindigkeit. Außer **CHEM 75-110** mit festen Stahlbuchse und **CHEM 90FC - 110FC** sind vorwärts gekrümmten Klinge.

Ventilatorbock und Lager

Die Ventilatorenböcke und Grundrahmen sind aus schweren Walzstahlprofilen hergestellt und feuerverzinkt. Dies bietet besten Schutz bei widrigsten Bedingungen. Spezielle Oberflächenbehandlungen sind auf Wunsch möglich. Der Ventilator kann in verschiedene Ausblasrichtungen gedreht werden.

Achsenwelle und Lager

Abgedrehte Präzisionswellen nach DIN 17210 - C45 mit einem glatten Anstrich. Beide Wellenenden haben Norm-Durchmesser nach DIN 748, Blatt 1 und Nuten nach DIN 6885, Blatt 1. Die Wellen sind zur Vermeidung von Korrosion chemisch widerstandsfähig beschichtet. Auf Anfrage können auch Wellen aus rostfreiem Stahl geliefert werden.

Die riemengetriebenen Ventilatoren der Typen **CHEM 125 - 400** besitzen Flanschlager aus Gußaluminium. Die Antriebswelle hat zwei spielfreie Standard-Rillenkugellager mit säurebeständiger Dichtung. Diese Konstruktion sichert störungsfreien Betrieb, ruhigen Lauf und minimale Schwingungen.

Für **CHEM 450** und größer werden die Antriebswellen mit Bocklager aus Gußeisen auf den Ventilatorbock montiert. Es werden entweder Pendelrollen- oder Pendelkugellager verwendet.

Antriebe

Genau gewuchtete Standard-Keilriemen-Scheiben mit Spannhülse, nach ISO 4183-1980. Alle Keilriemen entsprechend ISO 4148. Die Riementriebe werden entsprechend der benötigten Leistungen ausgewählt und korrekt verspannt was lange Standzeiten sicherstellt.

Chemical Resistant Centrifugal Plastic Fan Design

Casing

The fan casing is constructed from thermoplastic such as PP, PVC, PE, PVDF or Glass reinforced plastic -Vinyl ester grade (GRP or FRP). The fan casing is built to a true volute form and has high efficiency inlet cone to give an even distribution of air over the full width of the runner.

The smaller range of casing, model **CHEM 75 - 315** are completely plastic injection moulded. **CHEM 125 - 200** are suitable for dual rotation at any position, the plastic injection moulded backplate or inlet cover can be easily removed for changing of rotation, maintenance and services. Fans casing come with round straight outlet suitable for direct connection to flexible connector. Casing usually with PP as standard.

The **CHEM 400** casing usually of GRP construction or vacuum-formed and automatic machine welded. The plastic injection moulded backplate can be easily removed for maintenance and services. The GRP fans casing come with round straight outlet suitable for direct connection to flexible connector.

For larger range of fans (Models **CHEM 450 - 1250**), the casing is usually of GRP construction as standard or by mechanically machine welded as when required.

Chemco fan casing is extremely rigid with adequate thickness, properly stiffened to ensure it is free of vibration or drumming during operation. The casing is also constructed in a way that no metal parts are situated in the airflow to eliminate the risk of corrosion. Casing can be of GRP or any thermoplastic material blended with composites to overcome high temperature, flame retardant resistant, ultraviolet or Electrostatic Discharge protection to suit customer's requirements.

The inlet and outlet are of standard diameter sizes, which can be easily connected together with flexible connector during installation.

All casings can be fitted with drain outlets at the lowest point of the scrolls. This is to facilitate the drainage of condensation build-up or rainwater when installed in the open.

Radial Tip Backward Curve Impellers

Chemco fan impellers are of single inlet Single width (SISW) type. Impellers are of precision plastic injection moulded design with cast-in metal hub (Models **CHEM 75 - 315**) or mechanically welded construction (Models **CHEM 400 - 1250**) to highest quality standard with excellent aerodynamic properties.

Impeller is usually of PP however, depending on the type of applications; impeller can be made of PA, PC, PVC or PVDF. Impeller can be thermoplastic material blended with composites to overcome high temperature, flame retardant resistant, ultraviolet or Electrostatic Discharge protection to suit customer's requirements. Each impeller is statically and dynamically balanced in two planes in accordance with Q2.5 of VDI 2060 or Grade G2.5 of BS 5625 Part 1 (1979). The hubs are designed for use with taper-bushes and are made of high-grade cast plates to guarantee high reliability at the high peripheral speeds. Except **CHEM 75 - 110** with fixed steel bush and **CHEM 90FC - 110FC** are of forward curved blade.

Fan Base and Support

The fan supporting steel stands and fan bases are manufactured from heavy gauge mild steel and are hot dipped galvanised to provide maximum protection in the most adverse condition. Special surface treatment can be done on request. Fans can be rotated to suit different discharge directions.

Drive shaft and bearing

All precision solid shafts complying to DIN 17210 - C45 are trued and have a smooth finish. Both shaft ends have as standard feature diameters complying with DIN 748, Sheet 1 and grooved to DIN 6885, Sheet 1. The shafts are chemical resistant coated with protective cover to prevent corrosion. Upon requested, stainless steel shaft can also be provided.

CHEM 125 - 400 belt driven fans come with flange mounted aluminium cast bearing housings type. The drive shaft is fitted with two standards anti-friction grooved balls bearing unit with acid proof seal. This design ensures trouble-free service, silent operation and minimum vibration.

For **CHEM 450** and above, the drive shafts are mounted on fan pedestal with cast iron housing of plumber block units. These bearings are of self-aligning heavy-duty ball or spherical roller type.

Drives

Standard pulley drive with taper bush type, accurately balanced and conform to ISO 4183-1980 standards. All Vee belts are conform to ISO 4148. Belt section is selected with correct ratings and tensioning to ensure prolonged usage.

Motor

Je nach Anwendung sind Norm-Motoren von IP44, IP45, IP54 oder IP55 auf Anfrage lieferbar.

Bei direktgetriebene Ventilatoren werden B5 Flansch-Motore eingebaut, für riemengetriebene Ventilatoren, B3 Fuß-Motore. Alle Motoren sind vollständig geschlossen und luftgekühlt und erfüllen BS 2613. Die Standard-Motoren sind einphasig/dreiphasig, 50/60 Hertz passend für 240/415 oder 220/380 Volt. Andere Spannungen sind auf Anfrage lieferbar.

Tropenfestigkeit

Die Motor-Wicklungen sind mit Harz-Lacken ummantelt, welche den Motor passend für tropische Atmosphären machen. Zusätzlich Behandlungen können durchgeführt werden, wenn Motoren in extreme-tropischer Umgebung arbeiten sollen.

Explosionsschutz

Alle Ventilatoren mit Ex-Motoren sind für die folgenden Bereiche zugelassen:

- 1) BS 4683 Part II zertifiziert für die Gruppen IIa und IIb
- 2) BS 4683 Part IV, mit EXE bezeichnet und passed zum Gebrauch in Bereichen der Zone 1 für die Gruppen IIa und IIb.
- 3) BS 5000 Part 16 und BS 4683 Part III, mit EXN bezeichnete Typen, passend zum Gebrauchen in Bereichen der Zone 2.

EX-Schutz-Bereiche Zone 1 und 2, wenn innerhalb nicht explosionsgefährdeter Bereiche der Temperaturklassen T1-T3 installiert, aber nur unter den folgenden Bedingungen:

- a) Reduzierung der maximal erlaubten Drehzahl um 20%
- b) Reduzierung der erlaubt Antriebsleistung P_w um 30%
- c) nur Ventilatoren mit horizontalem Kanal verwenden
- d) der Ventilator muß mit Schutzgittern ausgestattet sein, die das Hineinfallen oder Angesaugtwerden von Fremdkörpern in den Ventilator wirkungsvoll verhindern.

Inspektionsöffnung/klappe

für Instandhaltung und Wartung. An den Typen CHEM 450 und größer kann auf Anfrage eine Inspektionsklappe angebracht werden. Diese Klappe erfüllt die allgemeinen Sicherheits- und Unfallverhütungsvorschriften, da sie nur unter der Verwendung von Werkzeuge geöffnet werden kann.

Zubehör

- Anbau von Feder-Schwingungsdämpfer
- Kondensatablaufstutzen mit Verschluss
- Motor, Motorschutz, Spannschlitten -Schienen, Riemenschutz, Riemenantrieb
- Lager, Abdeckung für Lager und Welle
- Ventilatorgrundrahmen
- Ansaugflansch, Ansaugmanschette mit Klemmband
- Splitter Schutzhaube.

wahlweise

- andere Farbe aus der gesamten Farbpalette
- flammhemmend
- Hochtemperatur
- elektrostatische Entladung – Anti-statisch, statisch verlustbehaftet oder leitend
- UV-beständig

Thermische und chemische Beständigkeit

Die Temperatur der Luft oder der Gase dürfen den für den Werkstoff angegebenen Wert nicht überschreiten:

Werkstoff	max. Temp. [°C]
PVC	60
PP	80
GFK	100
PVDF	120

Für ein ausführliche Liste der chemischen Anwendung wenden Sie sich bitte an unsere örtliche Vertretungen.

Motor

Depending on the application, standard electric driven motor of IP44, IP45, IP54 or IP55 can be supplied upon request.

For direct driven fans, motor are usually of B5 flange mounting and for belt driven fans, motor are of B3 foot mounting. All motors are totally enclosed and fan cooled complying with BS 2613. The motors are single/three phase, 50/60 Hz suitable for 240/415 or 220/380 volts standards. All other voltage can be supplied upon request.

Tropicalisation

Motor windings are coated with resin varnishes, which make the motor suitable for tropical atmospheres. Additional treatment can be carried out where motors are required to operate in severe tropical environments.

Flameproof

All fans mounted with flameproof motors are suitable in the following areas:

- 1) BS 4683 Part II certified for Groups IIa and IIb
- 2) BS 4683 Part IV designated EXE and are suitable for use in Zone 1 areas for group IIa and IIb.
- 3) BS 5000 Part 16 and BS 4683 Part III designated type EXN and suitable for use in Zone 2 areas.

Flameproof areas zone 1 and 2, when installed in non-explosion hazardous area for temperature categories T1-T3, but only under the follow conditions:

- a) the maximum allowed revolutions must be reduced by 20%
- b) the allowed drive power P_w should be reduced by 30%
- c) only fans with horizontal shafts are to be used
- d) fans must be equipped with guards to prevent foreign particulars falling in or being sucked in.

Inspection Door/Cover

For servicing and inspection purposes. For model CHEM 450 and above, an inspection cover can be included upon request. This cover is complies in general with safety and accident prevention regulations, as it can only be opened by using tools.

Accessories

- Anti-vibration spring mounting
- Condense water drain socket and plug
- Motor, motor guard, slide rails, belt guard, belt drive
- Bearing, bearing and shaft cover
- Fan and motor support base frame
- Inlet flanges, Inlet sleeve with clamping bands
- Splinter protection cover.

Optional

- Full range of colour matching
- Flame Retardant
- High Temperature
- Electrostatic Discharge - Anti-static, Static dissipative or Conductive
- Ultra Violet
- Frequency Invertor Speed Controller

Thermal and Chemical resistant

The temperature of the air and gases must not exceed that specified for the materials:

Material	max. Temp. [°C]
PVC	60
PP	80
GFK	100
PVDF	120

Please contact our local sales engineers for detailed list of Chemical Application Information.

Kennlinie Fan curve

CHEM 75R

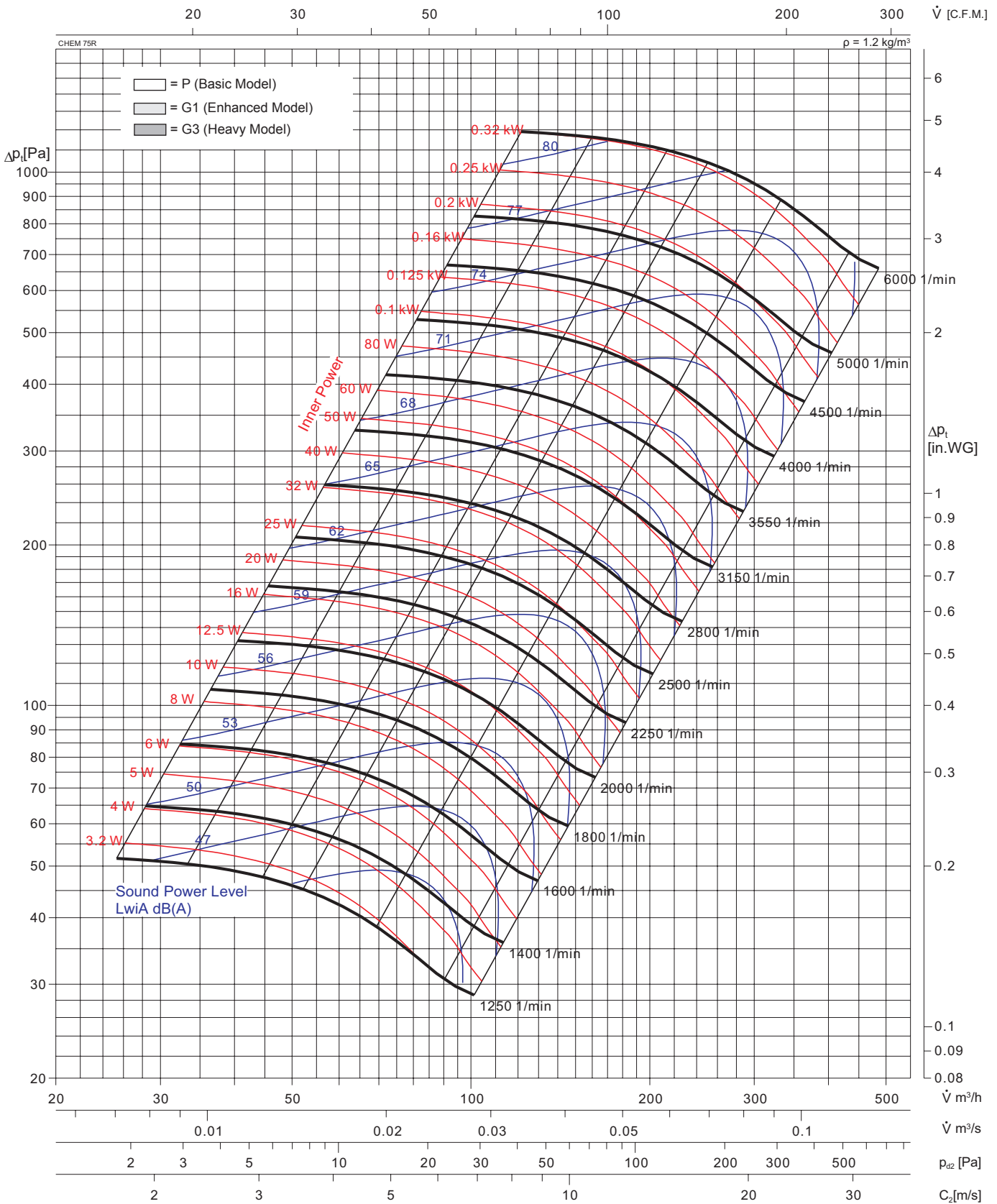

Im Kennfeld ist der A-bewertete Schalleistungspegel **L_{wiA}** angegeben.
Schalldruckpegel **L_{PA}** in 1,5 m Entfernung

A-weighted sound power level **L_{wiA}** is quoted in the diagram.
Sound pressure level **L_{PA}** at 1,5 m dist.

$$L_{PA} [\text{dB(A)}] = L_{wiA} - 14,5$$

Fan test laboratory AMCA 210/99 Fig.12, Test Chamber. Performance is for installation type D - Ducted inlet, Ducted outlet. Performance ratings do not include the effects of appurtenances (accessories-belt cover, pulley & belt).

The test data were obtained in a laboratory accredited by AMCA for AMCA Standard 210 and 300 testing.

Laurraddurchmesser	wheel diameter	D = 125 mm
Schaufelzahl	number of blades	z = 12
Gewicht	weight	G = 0,1 kg
Drehzahl maximal	speed limit	n_{max} = 6000 1/min

The A-weighted sound ratings shown have been calculated per AMCA International Standard 301. Values shown are for inlet L_{wiA} sound power levels for installation Type D: ducted inlet, ducted outlet. Ratings include the effects of duct end correction.

CHEM 75R is not licensed to bear the AMCA certified rating seal.

Kennlinie Fan curve

CHEM 90R

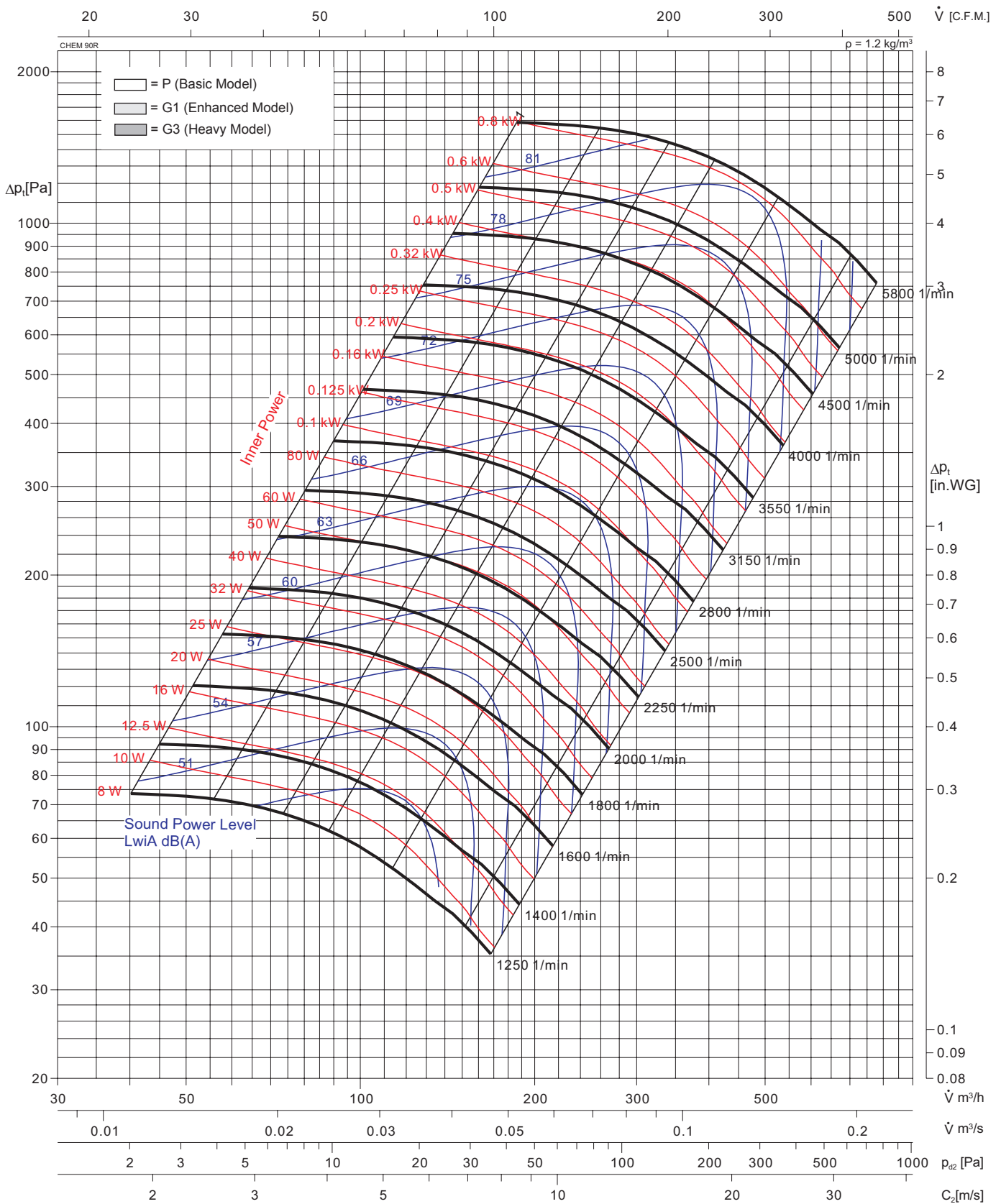

Im Kennfeld ist der A-bewertete Schalleistungspegel **LwiA** angegeben.
Schalldruckpegel L_{PA} in 1,5 m Entfernung

A-weighted sound power level **LwiA** is quoted in the diagram.
Sound pressure level L_{PA} at 1,5 m dist.

$$L_{PA} [\text{dB(A)}] = L_{wiA} - 14,5$$

Fan test laboratory AMCA 210/99 Fig.12, Test Chamber. Performance is for installation type D - Ducted inlet, Ducted outlet. Performance ratings do not include the effects of appurtenances (accessories-belt cover, pulley & belt).

The test data were obtained in a laboratory accredited by AMCA for AMCA Standard 210 and 300 testing.

Laufreddurchmesser	wheel diameter	D = 150 mm
Schaufelzahl	number of blades	z = 12
Gewicht	weight	G = 0,15 kg
Drehzahl maximal	speed limit	n_{max} = 5800 1/min

The A-weighted sound ratings shown have been calculated per AMCA International Standard 301. Values shown are for inlet LwiA sound power levels for installation Type D: ducted inlet, ducted outlet. Ratings include the effects of duct end correction.

CHEM 90R is not licensed to bear the AMCA certified rating seal.

Kennlinie Fan curve

CHEM 90FC

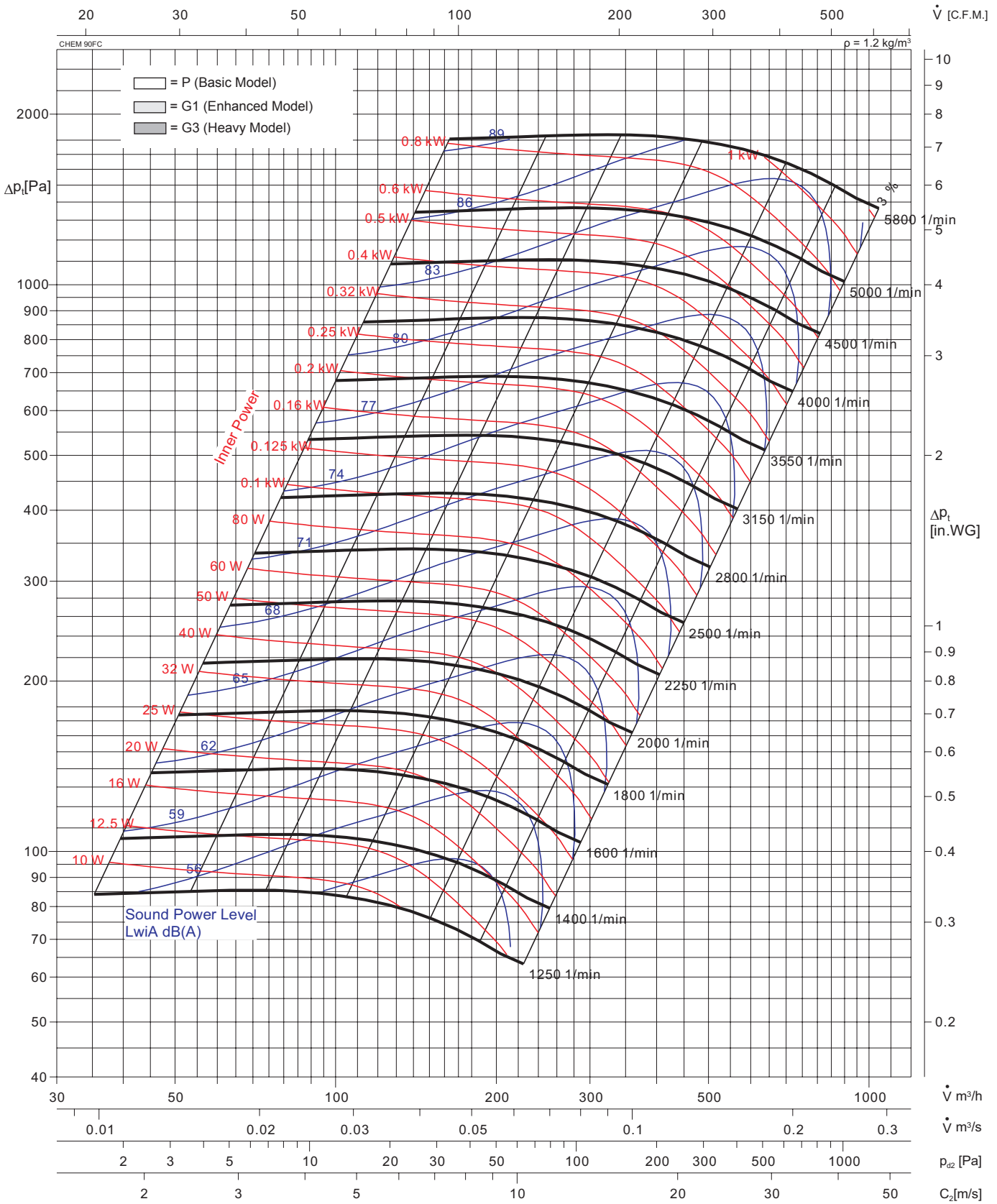

Im Kennfeld ist der A-bewertete Schalleistungsspegel **LwiA** angegeben.
Schalldruckpegel **L_{PA}** in 1,5 m Entfernung

A-weighted sound power level **LwiA** is quoted in the diagram.
Sound pressure level **L_{PA}** at 1,5 m dist.

$$L_{PA} [dB(A)] = L_{wiA} - 14,5$$

Laufraddurchmesser	wheel diameter	D = 150 mm
Schaufelzahl	number of blades	z = 35
Gewicht	weight	G = 0,19 kg
Drehzahl maximal	speed limit	n_{max} = 5800 1/min

Fan test laboratory AMCA 210/99 Fig.12, Test Chamber. Performance is for installation type D - Ducted inlet, Ducted outlet. Performance ratings do not include the effects of appurtenances (accessories-belt cover, pulley & belt).

The A-weighted sound ratings shown have been calculated per AMCA International Standard 301. Values shown are for inlet LwiA sound power levels for installation Type D: ducted inlet, ducted outlet. Ratings include the effects of duct end correction.

The test data were obtained in a laboratory accredited by AMCA for AMCA Standard 210 and 300 testing.

CHEM 90FC is not licensed to bear the AMCA certified rating seal.

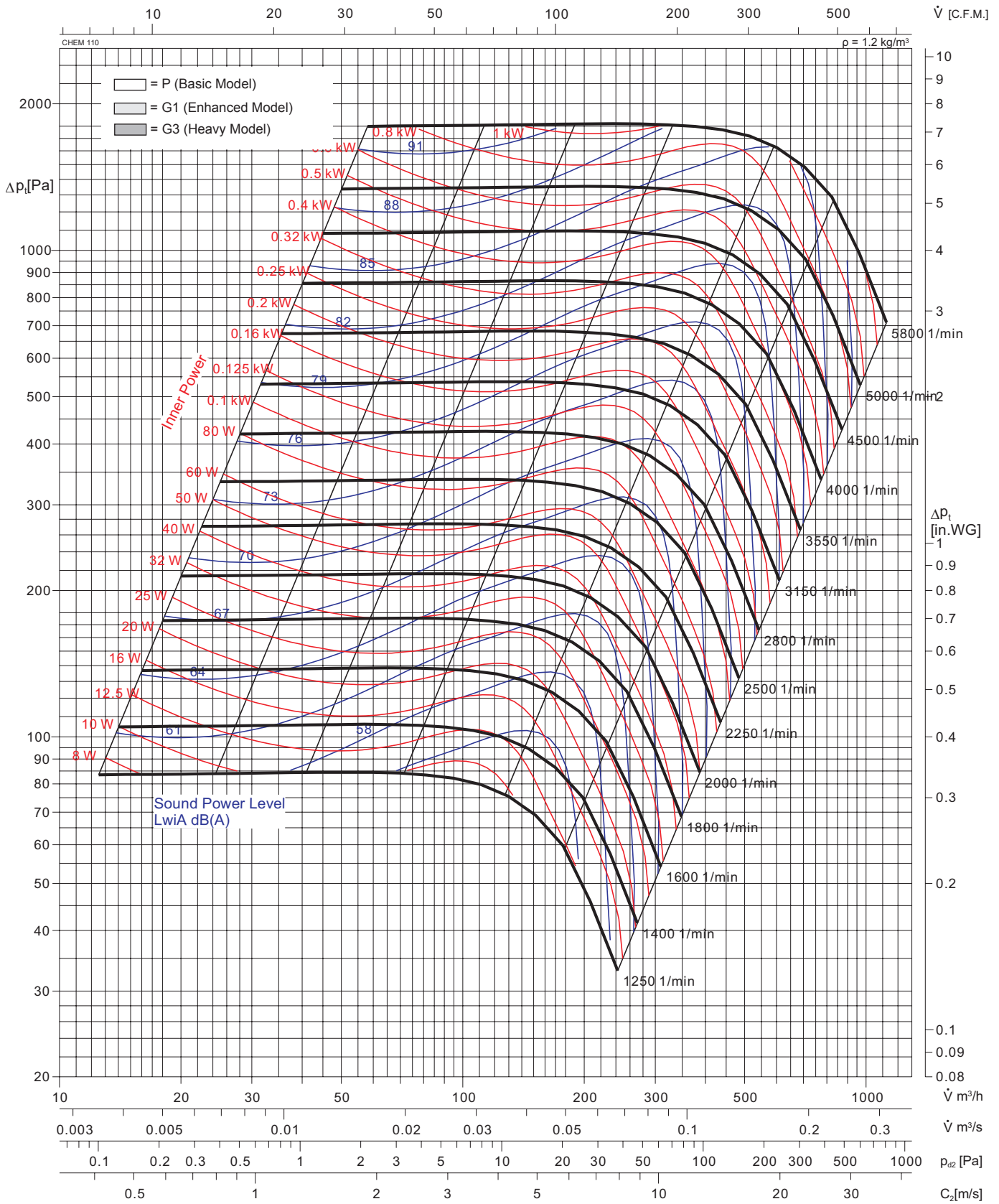

Im Kennfeld ist der A-bewertete Schalleistungspegel L_{wiA} angegeben.
Schalldruckpegel L_{PA} in 1,5 m Entfernung

A-weighted sound power level L_{wiA} is quoted in the diagram.
Sound pressure level L_{PA} at 1,5 m dist.

$$L_{PA} [\text{dB(A)}] = L_{wiA} - 14,5$$

Laufraddurchmesser	wheel diameter	D = 150 mm
Schaufelzahl	number of blades	z = 35
Gewicht	weight	G = 0,19 kg
Drehzahl maximal	speed limit	n_{max} = 5800 1/min

Fan test laboratory AMCA 210/99 Fig.12, Test Chamber. Performance is for installation type D - Ducted inlet, Ducted outlet. Performance ratings do not include the effects of appurtenances (accessories-belt cover, pulley & belt).

The A-weighted sound ratings shown have been calculated per AMCA International Standard 301. Values shown are for inlet L_{wiA} sound power levels for installation Type D: ducted inlet, ducted outlet. Ratings include the effects of duct end correction.

The test data were obtained in a laboratory accredited by AMCA for AMCA Standard 210 and 300 testing.

CHEM 110FC is not licensed to bear the AMCA certified rating seal.

Kennlinie Fan curve

CHEM 125

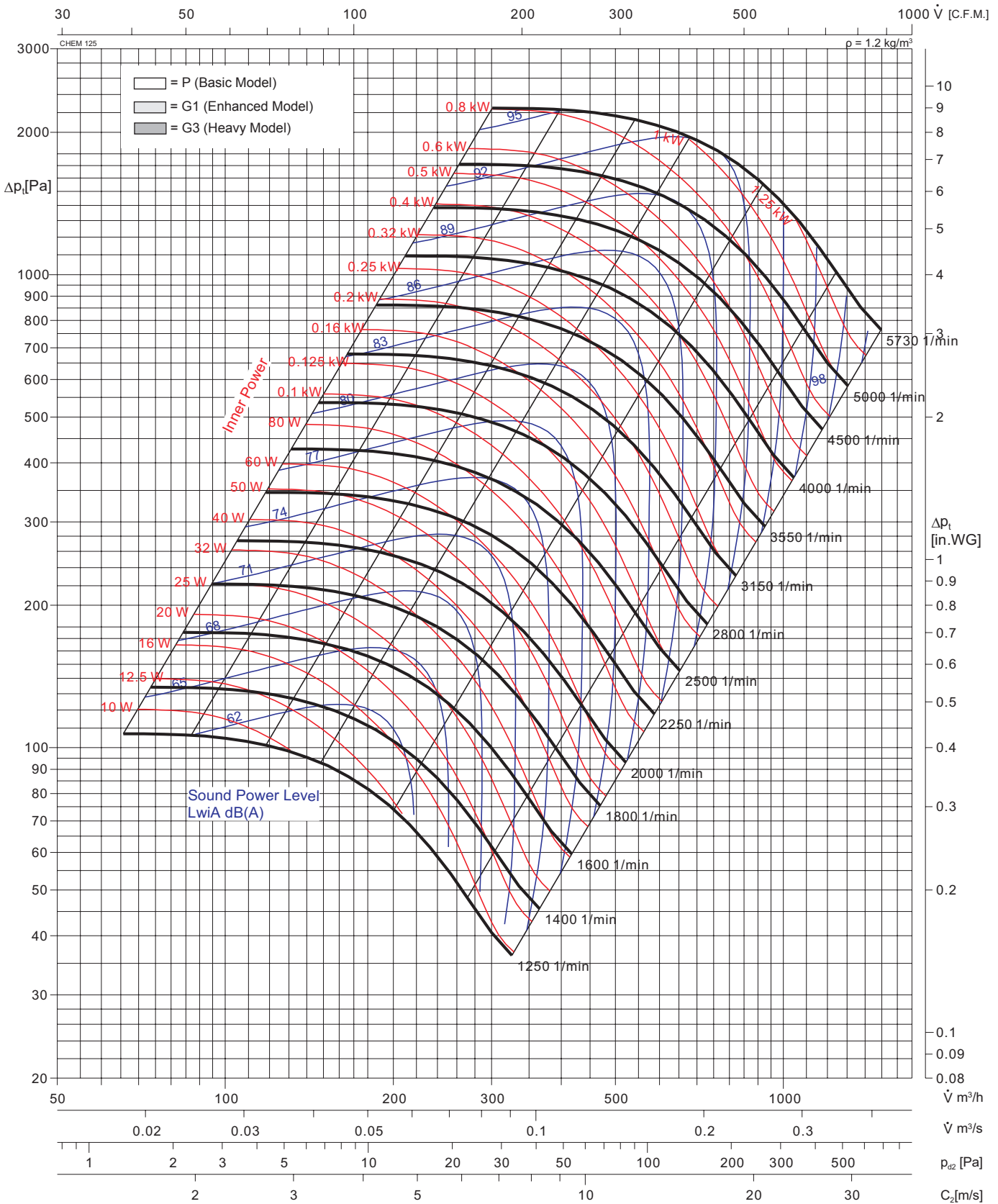

Im Kennfeld ist der A-bewertete Schalleistungspegel L_{wiA} angegeben.
Schalldruckpegel L_{PA} in 1,5 m Entfernung

A-weighted sound power level L_{wiA} is quoted in the diagram.
Sound pressure level L_{PA} at 1,5 m dist.

$$L_{PA} [\text{dB(A)}] = L_{wiA} - 14,5$$

Laufraddurchmesser	wheel diameter	D = 200 mm
Schaufelzahl	number of blades	z = 16
Gewicht	weight	G = 0,85 kg
Drehzahl maximal	speed limit	n_{max} = 5730 1/min

Fan test laboratory AMCA 210/99 Fig.12, Test Chamber. Performance is for installation type D - Ducted inlet, Ducted outlet. Performance ratings do not include the effects of appurtenances (accessories-belt cover, pulley & belt).

The A-weighted sound ratings shown have been calculated per AMCA International Standard 301. Values shown are for inlet L_{wiA} sound power levels for installation Type D: ducted inlet, ducted outlet. Ratings include the effects of duct end correction.

The test data were obtained in a laboratory accredited by AMCA for AMCA Standard 210 and 300 testing.

CHEM 125 is not licensed to bear the AMCA certified rating seal.

Kennlinie Fan curve

CHEM 160

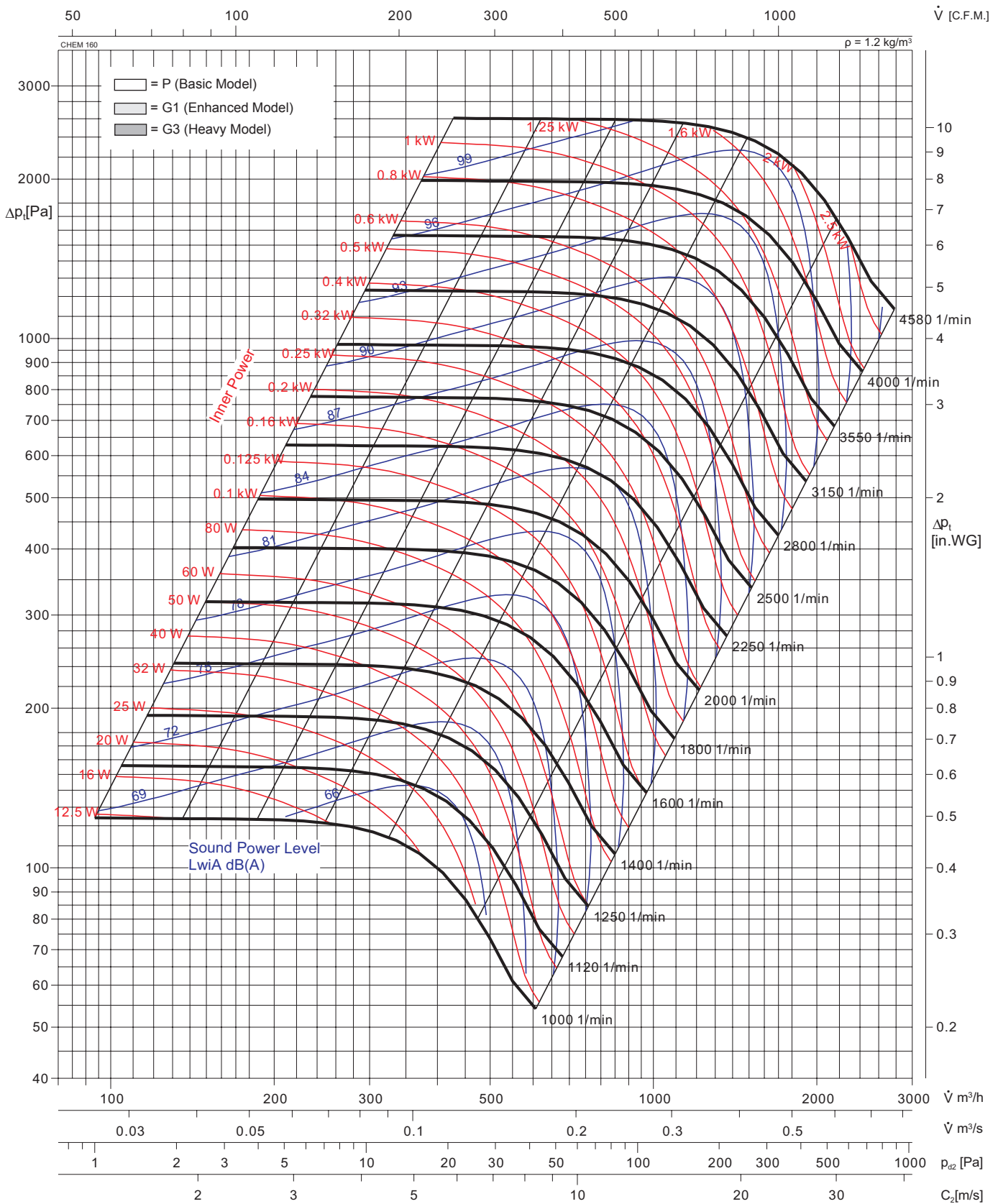

Im Kennfeld ist der A-bewertete Schalleistungspegel **L_{wiA}** angegeben.
Schalldruckpegel **L_{pA}** in 1,5 m Entfernung

A-weighted sound power level **L_{wiA}** is quoted in the diagram.
Sound pressure level **L_{pA}** at 1,5 m dist.

$$L_{pA} [dB(A)] = L_{wiA} - 14,5$$

Lauferraddurchmesser	wheel diameter	D = 250 mm
Schaufelzahl	number of blades	z = 16
Gewicht	weight	G = 0,95 kg
Drehzahl maximal	speed limit	n_{max} = 4580 1/min

Fan test laboratory AMCA 210/99 Fig.12, Test Chamber. Performance is for installation type D - Ducted inlet, Ducted outlet. Performance ratings do not include the effects of appurtenances (accessories-belt cover, pulley & belt).

The A-weighted sound ratings shown have been calculated per AMCA International Standard 301. Values shown are for inlet L_{wiA} sound power levels for installation Type D: ducted inlet, ducted outlet. Ratings include the effects of duct end correction.

The test data were obtained in a laboratory accredited by AMCA for AMCA Standard 210 and 300 testing.

CHEM 160 is not licensed to bear the AMCA certified rating seal.

Kennlinie Fan curve

CHEM 180

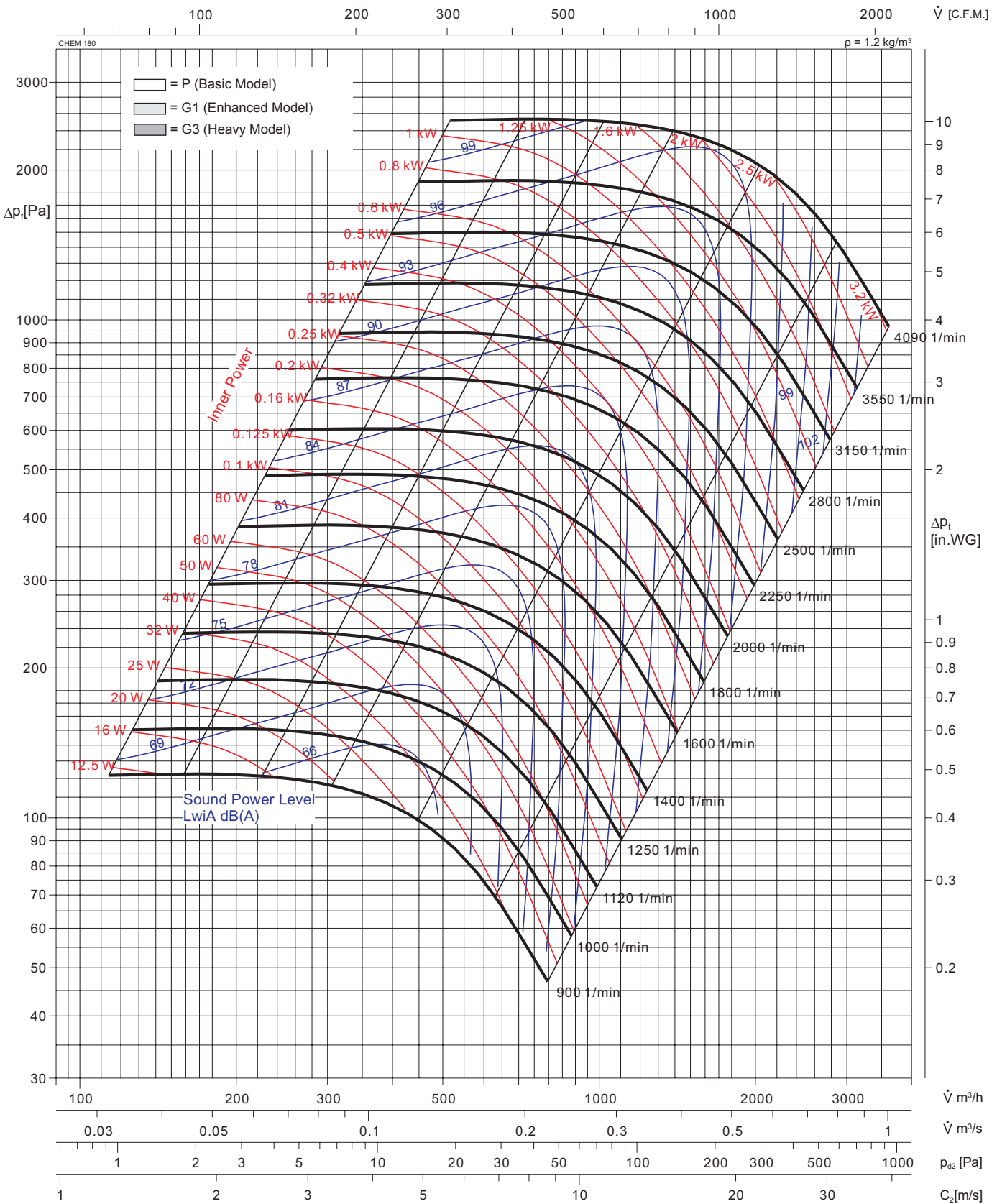

Im Kennfeld ist der A-bewertete Schalleistungspegel **LwiA** angegeben.
Schalldruckpegel L_{PA} in 1,5 m Entfernung

A-weighted sound power level **LwiA** is quoted in the diagram.
Sound pressure level L_{PA} at 1,5 m dist.

$$L_{PA} [dB(A)] = L_{wiA} - 14,5$$

Laufraddurchmesser	wheel diameter	D = 280 mm
Schaufelzahl	number of blades	z = 20
Gewicht	weight	G = 1,0 kg
Drehzahl maximal	speed limit	n_{max} = 4090 1/min

Fan test laboratory AMCA 210/99 Fig.12, Test Chamber. Performance is for installation type D - Ducted inlet, Ducted outlet. Performance ratings do not include the effects of appurtenances (accessories-belt cover, pulley & belt).

The A-weighted sound ratings shown have been calculated per AMCA International Standard 301. Values shown are for inlet LwiA sound power levels for installation Type D: ducted inlet, ducted outlet. Ratings include the effects of duct end correction.

The test data were obtained in a laboratory accredited by AMCA for AMCA Standard 210 and 300 testing.

CHEM 180 is not licensed to bear the AMCA certified rating seal.

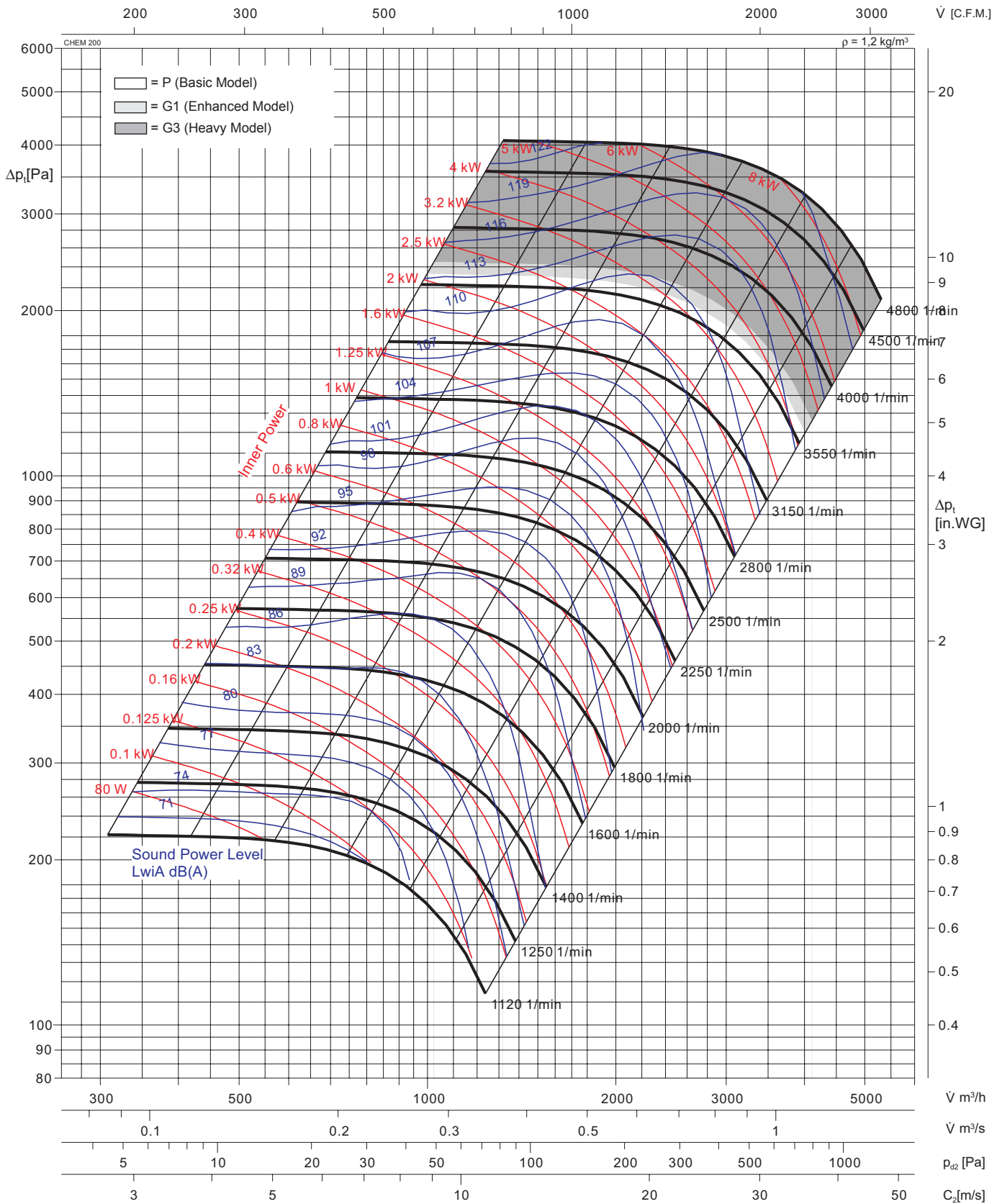

Im Kennfeld ist der A-bewertete Schalleistungspegel **L_{wiA}** angegeben.
Schalldruckpegel **L_{pA}** in 1,5 m Entfernung

A-weighted sound power level **L_{wiA}** is quoted in the diagram.
Sound pressure level **L_{pA}** at 1,5 m dist.

$$L_{pA} [\text{dB(A)}] = L_{wiA} - 14,5$$

Laufreddurchmesser	wheel diameter	D = 317 mm
Schaufelzahl	number of blades	z = 20
Gewicht	weight	G = 1,2 kg
Drehzahl maximal	speed limit	n_{max} = 4800 1/min

Fan test laboratory AMCA 210/99 Fig.12, Test Chamber. Performance certified is for installation type D - Ducted inlet, Ducted outlet. Power Rating (kW) does not include transmission losses. Performance ratings do not include the effects of appurtenances (accessories).

The A-weighted sound ratings shown have been calculated per AMCA International Standard 301. Values shown are for inlet L_{wiA} sound power levels for installation Type D: ducted inlet, ducted outlet. Ratings include the effects of duct end correction.

The test data were obtained in a laboratory accredited by AMCA for AMCA Standard 210 and 300 testing.

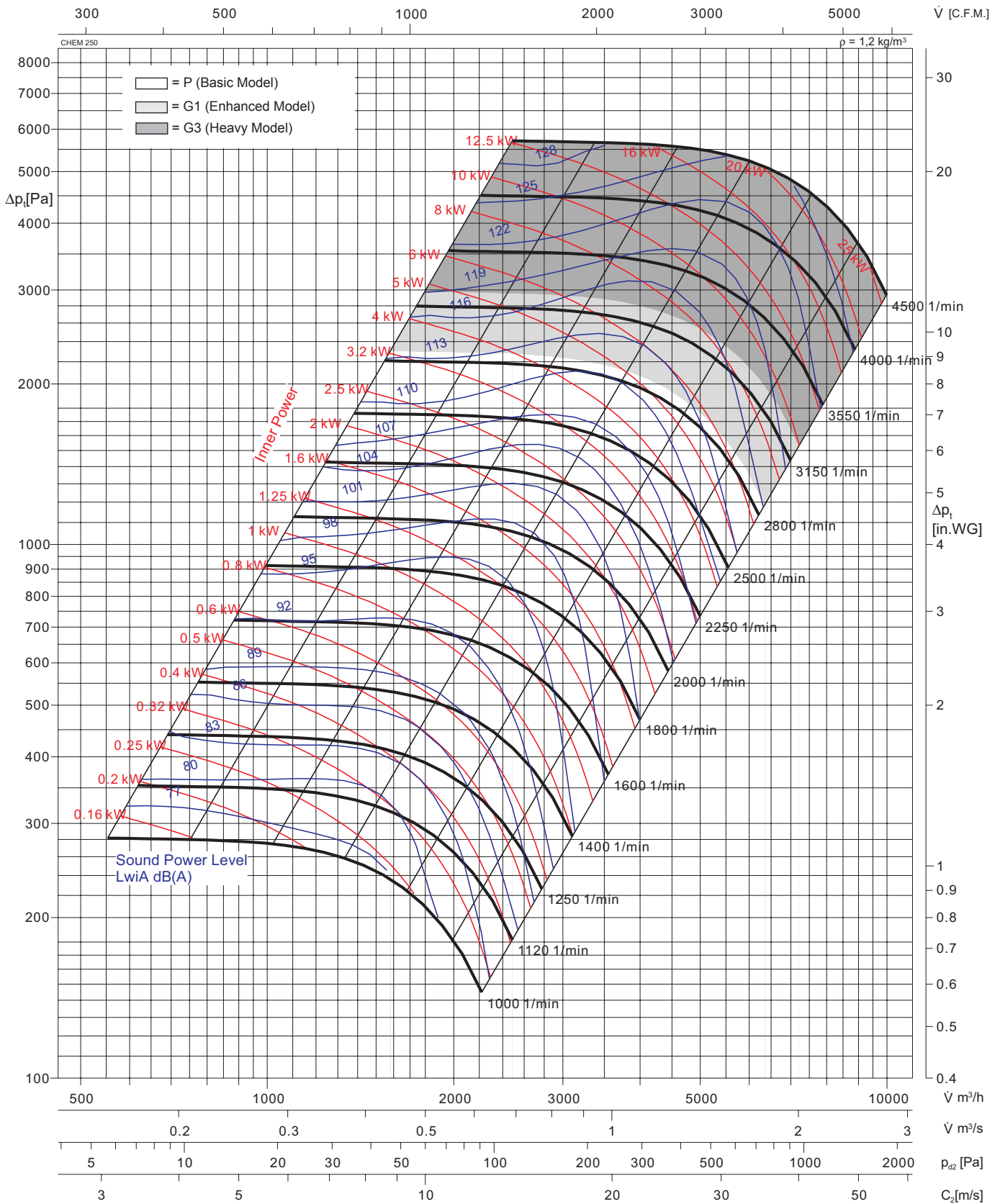

Im Kennfeld ist der A-bewertete Schalleistungsspegel **LwiA** angegeben.
Schalldruckpegel L_{PA} in 1,5 m Entfernung

A-weighted sound power level **LwiA** is quoted in the diagram.
Sound pressure level L_{PA} at 1,5 m dist.

$$L_{PA} [\text{dB(A)}] = L_{wiA} - 14,5$$

Fan test laboratory AMCA 210/99 Fig.12, Test Chamber. Performance certified is for installation type D - Ducted inlet, Ducted outlet. Power Rating (kW) does not include transmission losses, Performance ratings do not include the effects of appurtenances (accessories).

The test data were obtained in a laboratory accredited by AMCA for AMCA Standard 210 and 300 testing.

Laurraddurchmesser	wheel diameter	D = 400 mm
Schaufelzahl	number of blades	z = 20
Gewicht	weight	G = 1,8 kg
Drehzahl maximal	speed limit	n_{max} = 4500 1/min

The A-weighted sound ratings shown have been calculated per AMCA International Standard 301. Values shown are for inlet LwiA sound power levels for installation Type D: ducted inlet, ducted outlet. Ratings include the effects of duct end correction.

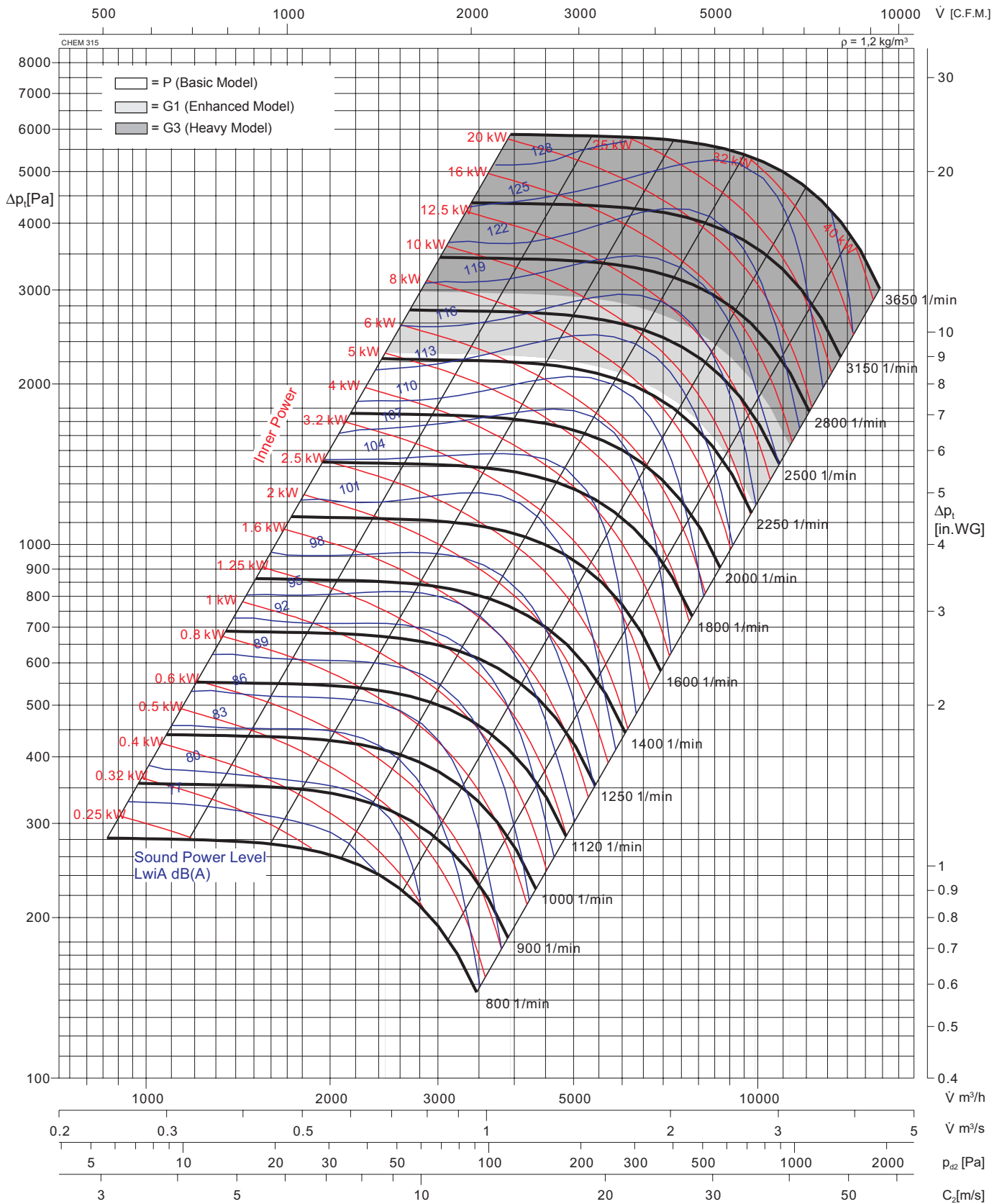

Im Kennfeld ist der A-bewertete Schalleistungspegel **L_{wiA}** angegeben.
Schalldruckpegel **L_{PA}** in 1,5 m Entfernung

A-weighted sound power level **L_{wiA}** is quoted in the diagram.
Sound pressure level **L_{PA}** at 1,5 m dist.

$$L_{PA} [\text{dB(A)}] = L_{wiA} - 14,5$$

Laufreddurchmesser	wheel diameter	D = 500 mm
Schaufelzahl	number of blades	z = 20
Gewicht	weight	G = 2,7 kg
Drehzahl maximal	speed limit	n_{max} = 3650 1/min

Fan test laboratory AMCA 210/99 Fig.12, Test Chamber. Performance certified is for installation type D - Ducted inlet, Ducted outlet. Power Rating (kW) does not include transmission losses. Performance ratings do not include the effects of appurtenances (accessories).

The A-weighted sound ratings shown have been calculated per AMCA International Standard 301. Values shown are for inlet L_{wiA} sound power levels for installation Type D: ducted inlet, ducted outlet. Ratings include the effects of duct end correction.

The test data were obtained in a laboratory accredited by AMCA for AMCA Standard 210 and 300 testing.

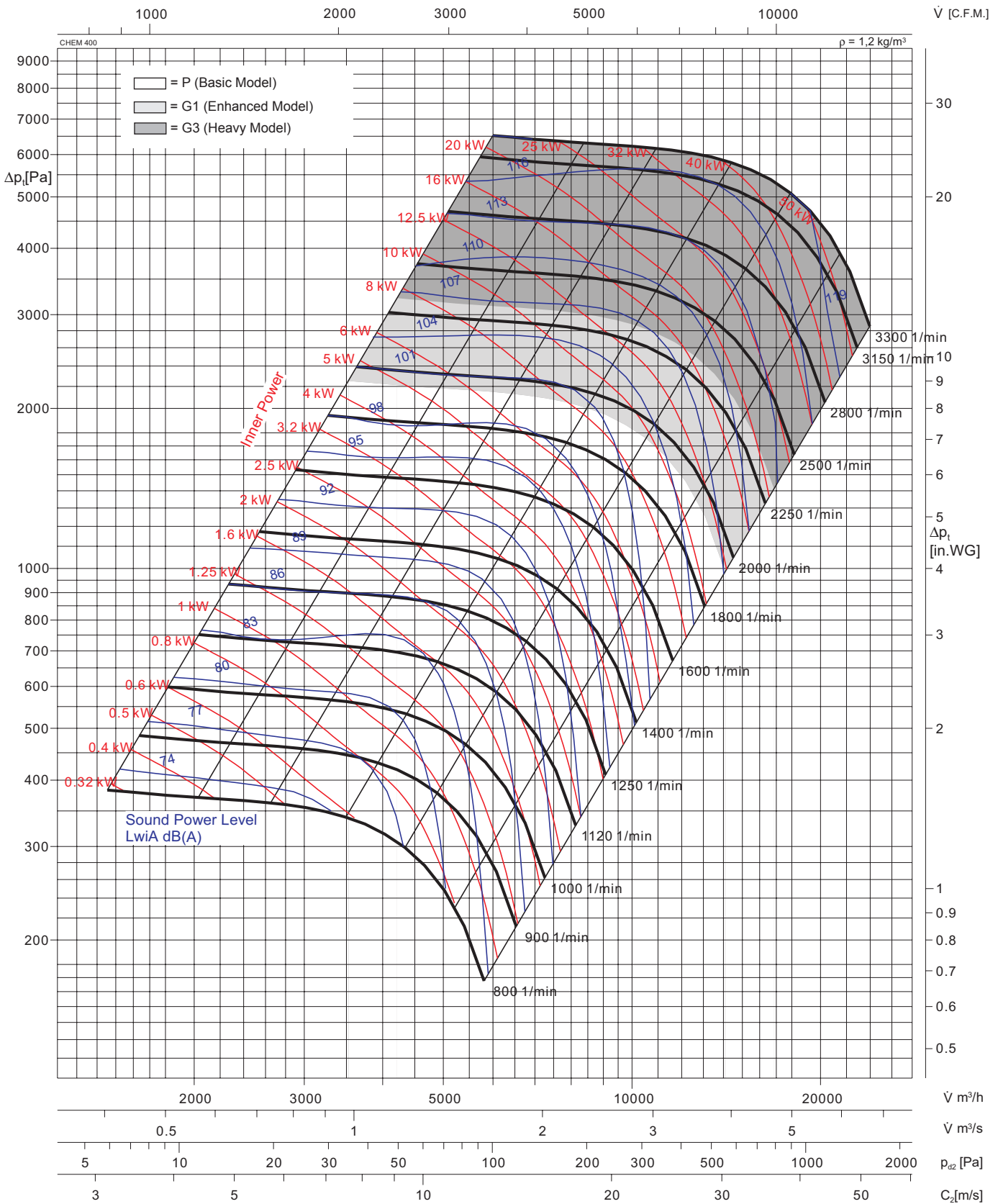

Im Kennfeld ist der A-bewertete Schalleistungspegel **L_{wiA}** angegeben.
Schalldruckpegel **L_{PA}** in 1,5 m Entfernung Sound pressure level **L_{PA}** at 1,5 m dist.

$$L_{PA} [\text{dB(A)}] = L_{wiA} - 14,5$$

Laufreddurchmesser	wheel diameter	D = 560 mm
Schaufelzahl	number of blades	z = 20
Gewicht	weight	G = 11 kg
Drehzahl maximal	speed limit	n_{max} = 3300 1/min

Fan test laboratory AMCA 210/99 Fig.12, Test Chamber. Performance certified is for installation type D - Ducted inlet, Ducted outlet. Power Rating (kW) does not include transmission losses, Performance ratings do not include the effects of appurtenances (accessories).

The A-weighted sound ratings shown have been calculated per AMCA International Standard 301. Values shown are for inlet L_{wiA} sound power levels for installation Type D: ducted inlet, ducted outlet. Ratings include the effects of duct end correction.

The test data were obtained in a laboratory accredited by AMCA for AMCA Standard 210 and 300 testing.

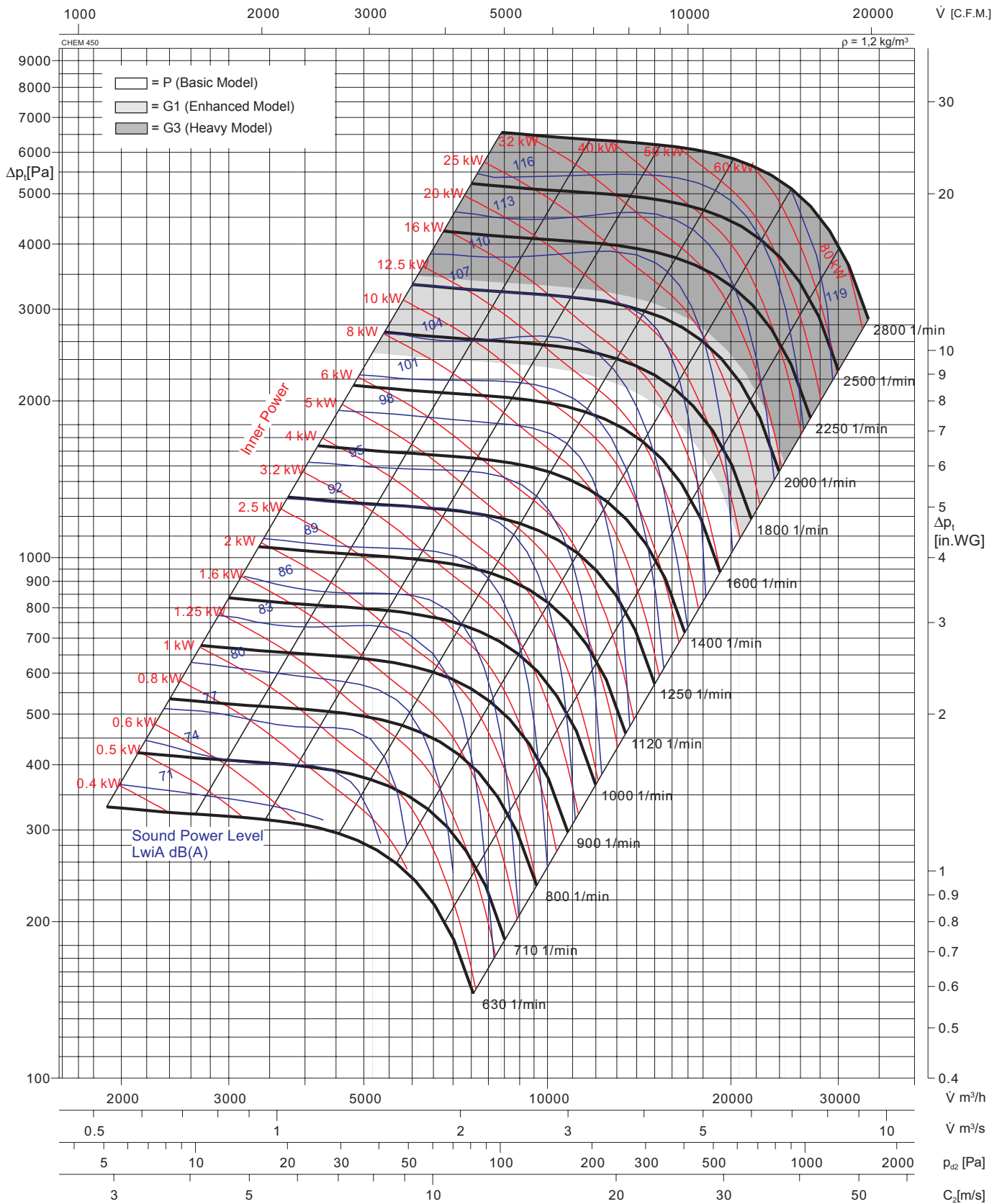

Im Kennfeld ist der A-bewertete Schalleistungspegel **LwA** angegeben.
Schalldruckpegel **L_{PA}** in 1,5 m Entfernung

A-weighted sound power level **LwA** is quoted in the diagram.
Sound pressure level **L_{PA}** at 1,5 m dist.

$$L_{PA} [dB(A)] = LwA - 14,5$$

Lauffraddurchmesser	wheel diameter	D = 662 mm
Schaufelzahl	number of blades	z = 20
Gewicht	weight	G = 17,5 kg
Drehzahl maximal	speed limit	n_{max} = 2800 1/min

Fan test laboratory AMCA 210/99 Fig.12, Test Chamber. Performance certified is for installation type D - Ducted inlet, Ducted outlet. Power Rating (kW) does not include transmission losses. Performance ratings do not include the effects of appurtenances (accessories).

The A-weighted sound ratings shown have been calculated per AMCA International Standard 301. Values shown are for inlet LwA sound power levels for installation Type D: ducted inlet, ducted outlet. Ratings include the effects of duct end correction.

The test data were obtained in a laboratory accredited by AMCA for AMCA Standard 210 and 300 testing.

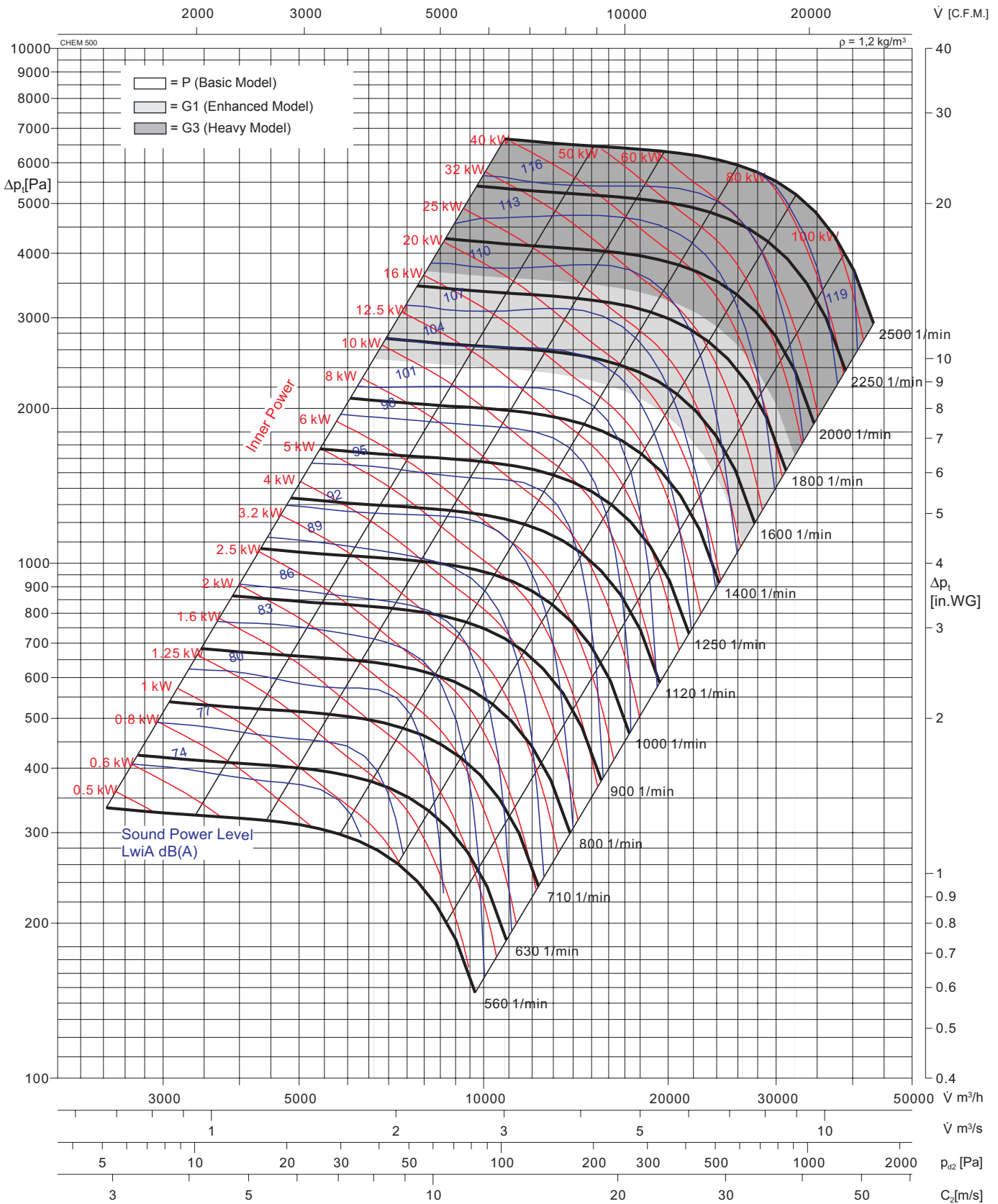

Im Kennfeld ist der A-bewertete Schalleistungsspegel **LwiA** angegeben.
Schalldruckpegel L_{PA} in 1,5 m Entfernung

A-weighted sound power level **LwiA** is quoted in the diagram.
Sound pressure level L_{PA} at 1,5 m dist.

$$L_{PA} [\text{dB(A)}] = L_{wiA} - 14,5$$

Laufraddurchmesser	wheel diameter	D = 748 mm
Schaufelzahl	number of blades	z = 20
Gewicht	weight	G = 22 kg
Drehzahl maximal	speed limit	n_{max} = 2500 1/min

Fan test laboratory AMCA 210/99 Fig.12, Test Chamber. Performance certified is for installation type D - Ducted inlet, Ducted outlet. Power Rating (kW) does not include transmission losses, Performance ratings do not include the effects of appurtenances (accessories).

The A-weighted sound ratings shown have been calculated per AMCA International Standard 301. Values shown are for inlet LwiA sound power levels for installation Type D: ducted inlet, ducted outlet. Ratings include the effects of duct end correction.

The test data were obtained in a laboratory accredited by AMCA for AMCA Standard 210 and 300 testing.

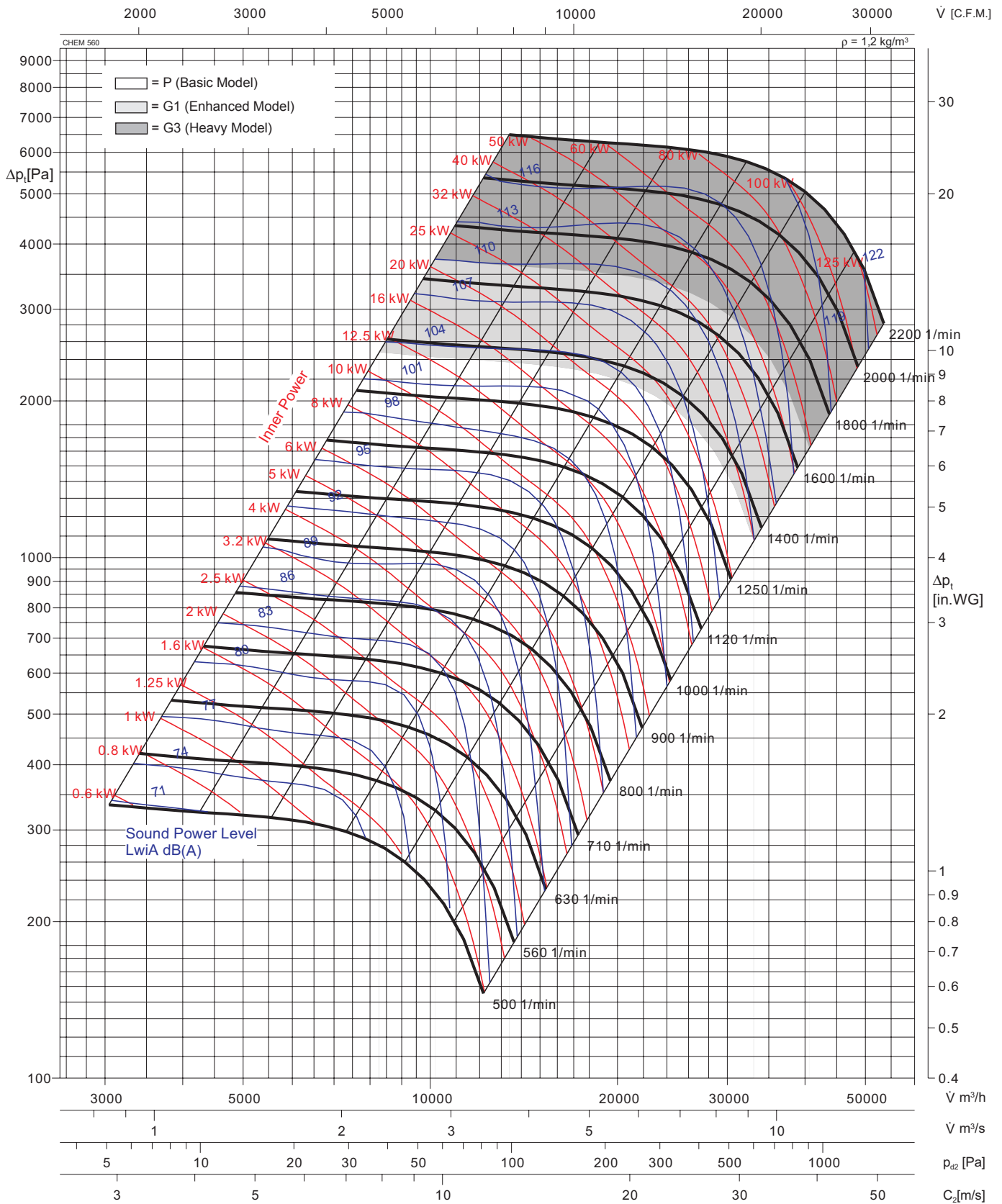

Im Kennfeld ist der A-bewertete Schalleistungspegel **L_{wiA}** angegeben.
Schalldruckpegel **L_{PA}** in 1,5 m Entfernung

A-weighted sound power level **L_{wiA}** is quoted in the diagram.
Sound pressure level **L_{PA}** at 1,5 m dist.

$$L_{PA} [\text{dB(A)}] = L_{wiA} - 14,5$$

Laufreddurchmesser	wheel diameter	D = 841 mm
Schaufelzahl	number of blades	z = 20
Gewicht	weight	G = 26,5 kg
Drehzahl maximal	speed limit	n_{max} = 2200 1/min

Fan test laboratory AMCA 210/99 Fig.12, Test Chamber. Performance certified is for installation type D - Ducted inlet, Ducted outlet. Power Rating (kW) does not include transmission losses. Performance ratings do not include the effects of appurtenances (accessories).

The A-weighted sound ratings shown have been calculated per AMCA International Standard 301. Values shown are for inlet L_{wiA} sound power levels for installation Type D: ducted inlet, ducted outlet. Ratings include the effects of duct end correction.

The test data were obtained in a laboratory accredited by AMCA for AMCA Standard 210 and 300 testing.

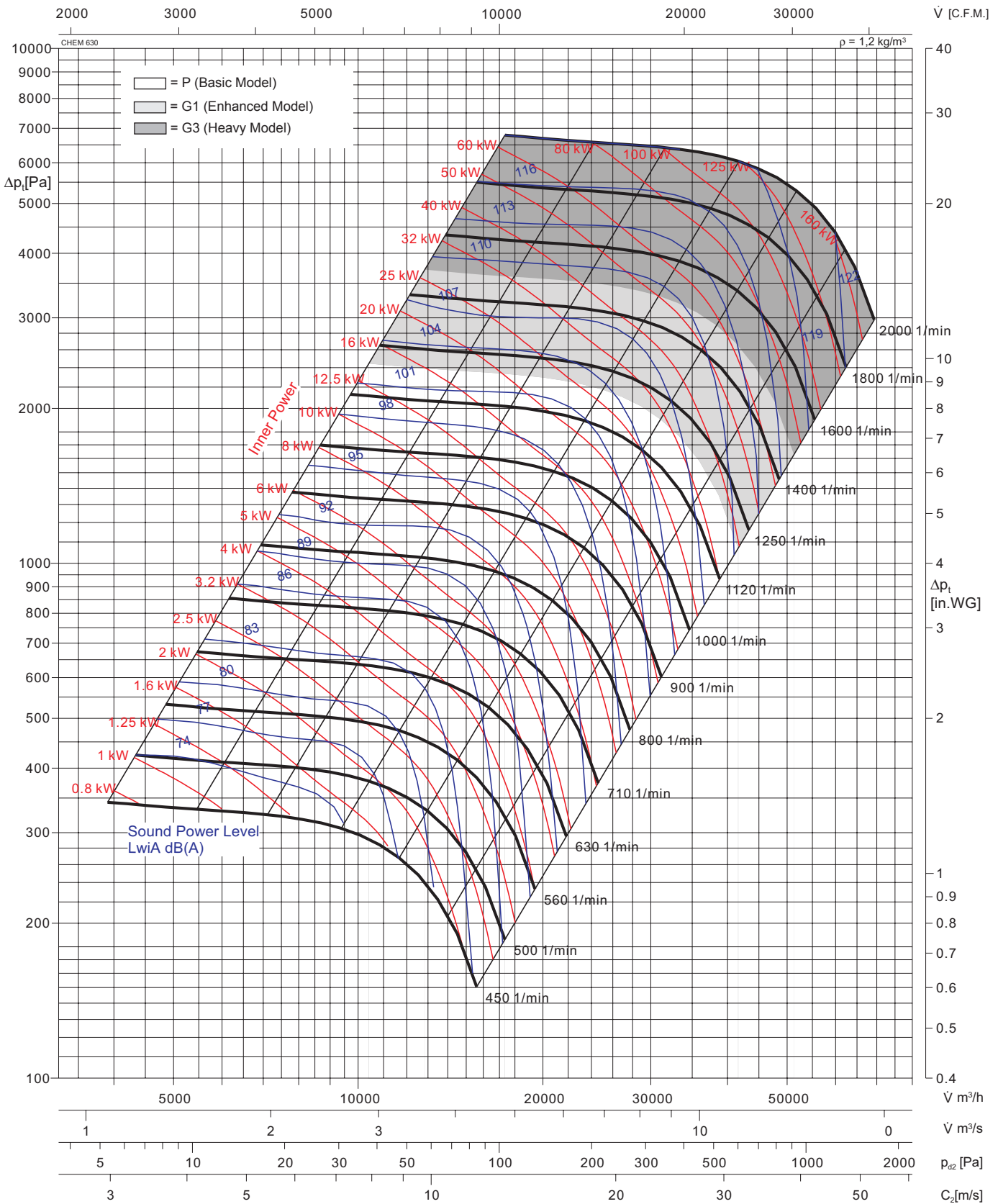

Im Kennfeld ist der A-bewertete Schalleistungspegel **LwiA** angegeben.
Schalldruckpegel L_{PA} in 1,5 m Entfernung

A-weighted sound power level **LwiA** is quoted in the diagram.
Sound pressure level L_{PA} at 1,5 m dist.

$$L_{PA} [\text{dB(A)}] = L_{wiA} - 14,5$$

Laufraddurchmesser	wheel diameter	D = 943 mm
Schaufelzahl	number of blades	z = 20
Gewicht	weight	G = 35 kg
Drehzahl maximal	speed limit	n_{max} = 2000 1/min

Fan test laboratory AMCA 210/99 Fig.12, Test Chamber. Performance certified is for installation type D - Ducted inlet, Ducted outlet. Power Rating (kW) does not include transmission losses, Performance ratings do not include the effects of appurtenances (accessories).

The A-weighted sound ratings shown have been calculated per AMCA International Standard 301. Values shown are for inlet LwiA sound power levels for installation Type D: ducted inlet, ducted outlet. Ratings include the effects of duct end correction.

The test data were obtained in a laboratory accredited by AMCA for AMCA Standard 210 and 300 testing.

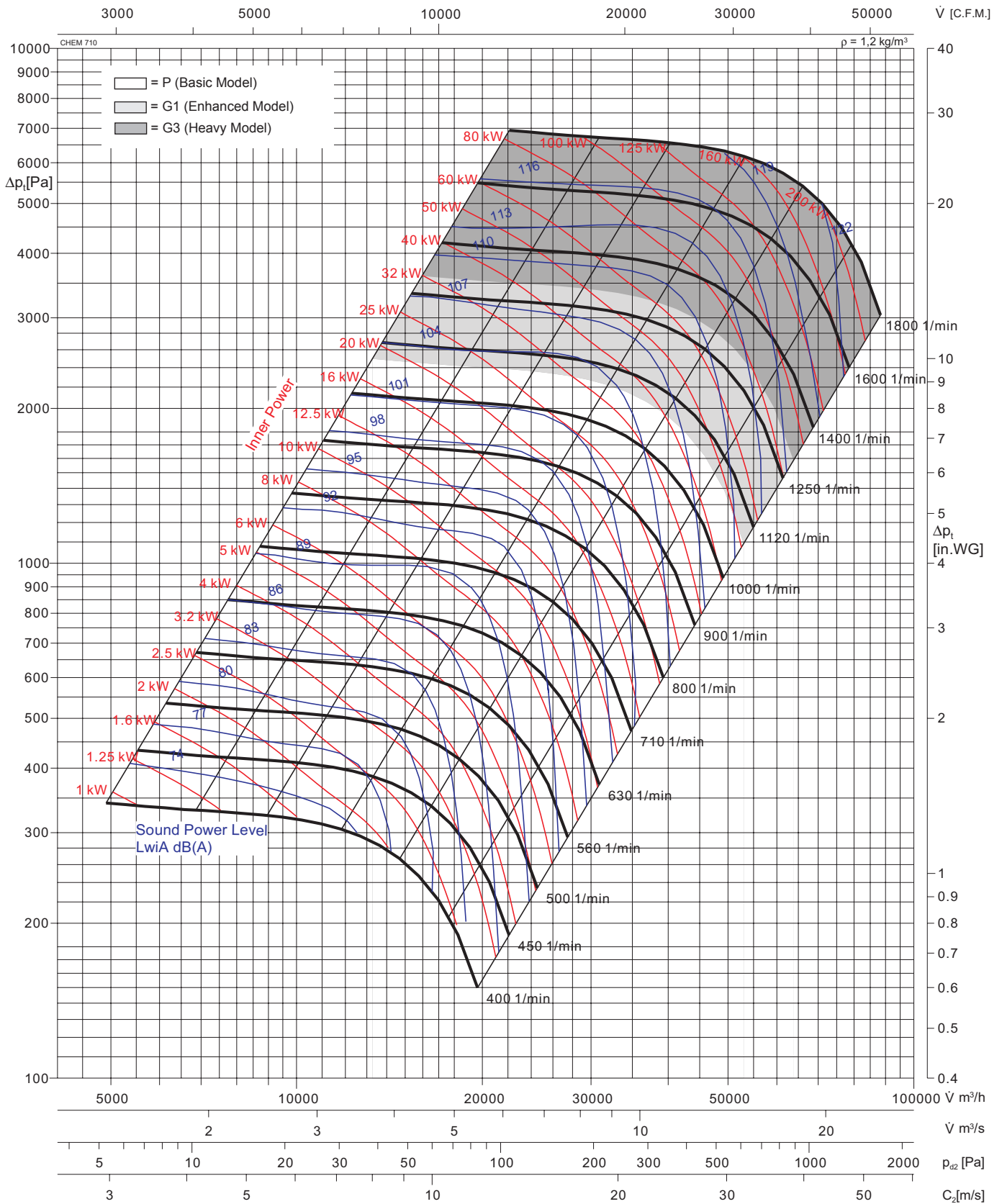

Im Kennfeld ist der A-bewertete Schalleistungspegel **LwiA** angegeben.
Schalldruckpegel L_{PA} in 1,5 m Entfernung

A-weighted sound power level **LwiA** is quoted in the diagram.
Sound pressure level L_{PA} at 1,5 m dist.

$$L_{PA} [\text{dB(A)}] = L_{wiA} - 14,5$$

Laufreddurchmesser	wheel diameter	D = 1059 mm
Schaufelzahl	number of blades	z = 20
Gewicht	weight	G = 45 kg
Drehzahl maximal	speed limit	n_{max} = 1800 1/min

Fan test laboratory AMCA 210/99 Fig.12, Test Chamber. Performance certified is for installation type D - Ducted inlet, Ducted outlet. Power Rating (kW) does not include transmission losses. Performance ratings do not include the effects of appurtenances (accessories).

The A-weighted sound ratings shown have been calculated per AMCA International Standard 301. Values shown are for inlet LwiA sound power levels for installation Type D: ducted inlet, ducted outlet. Ratings include the effects of duct end correction.

The test data were obtained in a laboratory accredited by AMCA for AMCA Standard 210 and 300 testing.

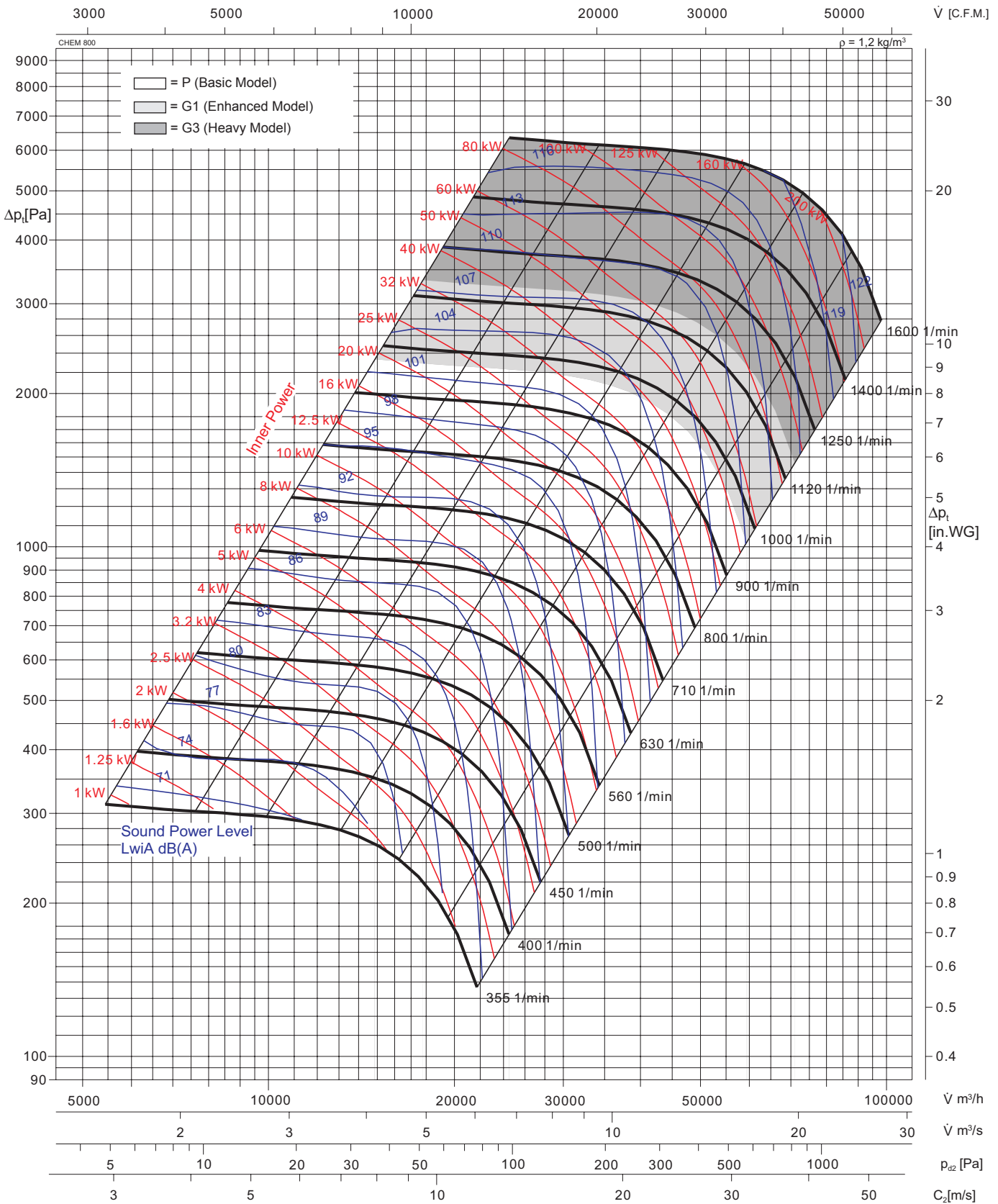

Im Kennfeld ist der A-bewertete Schalleistungspegel **L_{wiA}** angegeben.
Schalldruckpegel **L_{PA}** in 1,5 m Entfernung

A-weighted sound power level **L_{wiA}** is quoted in the diagram.
Sound pressure level **L_{PA}** at 1,5 m dist.

$$L_{PA} [\text{dB(A)}] = L_{wiA} - 14,5$$

Laurraddurchmesser	wheel diameter	D = 1140 mm
Schaufelzahl	number of blades	z = 20
Gewicht	weight	G = 75 kg
Drehzahl maximal	speed limit	n_{max} = 1600 1/min

Fan test laboratory AMCA 210/99 Fig.12, Test Chamber. Performance certified is for installation type D - Ducted inlet, Ducted outlet. Power Rating (kW) does not include transmission losses. Performance ratings do not include the effects of appurtenances (accessories).

The A-weighted sound ratings shown have been calculated per AMCA International Standard 301. Values shown are for inlet L_{wiA} sound power levels for installation Type D: ducted inlet, ducted outlet. Ratings include the effects of duct end correction.

The test data were obtained in a laboratory accredited by AMCA for AMCA Standard 210 and 300 testing.

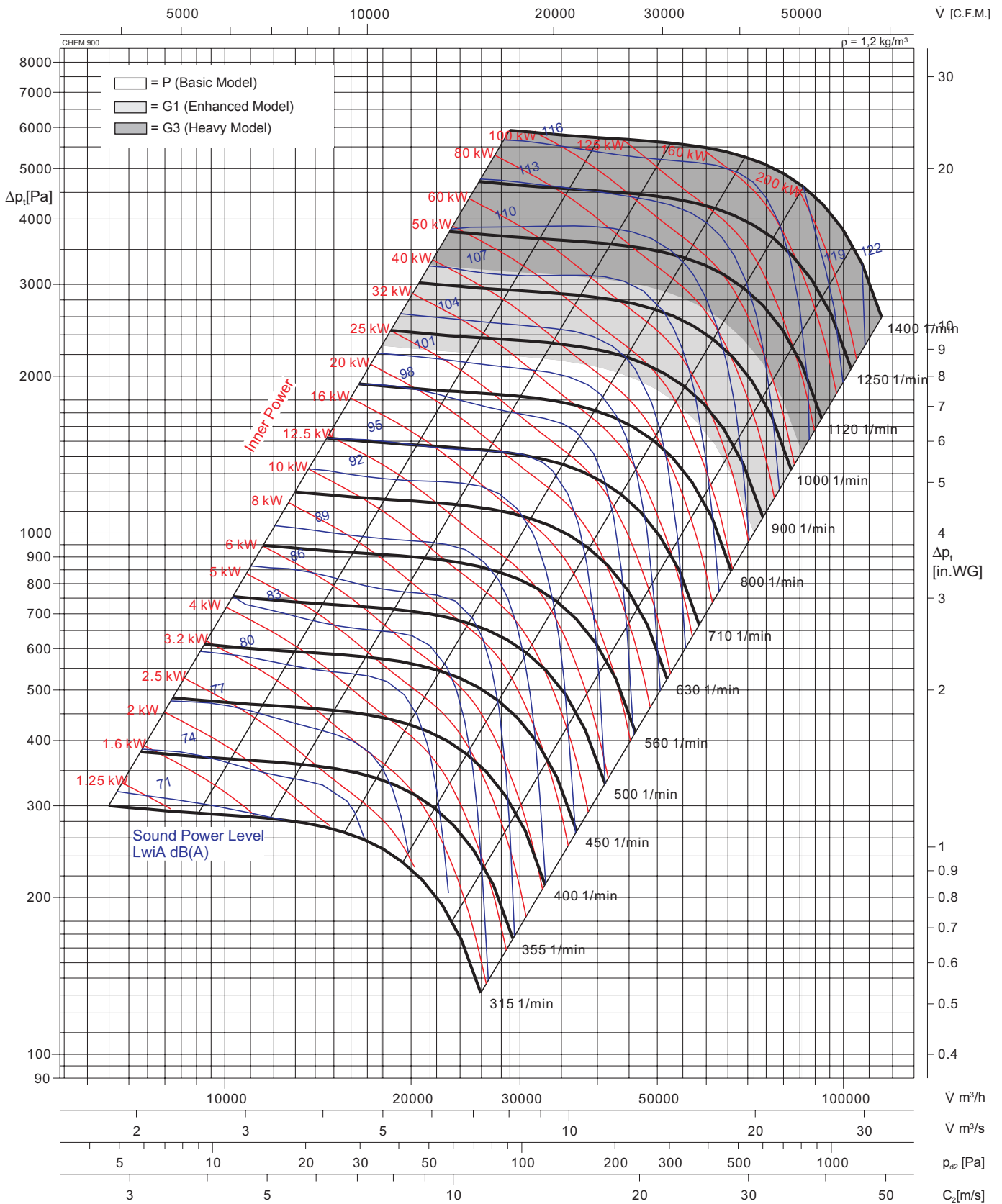

Im Kennfeld ist der A-bewertete Schalleistungspegel **LwiA** angegeben.
Schalldruckpegel L_{PA} in 1,5 m Entfernung

A-weighted sound power level **LwiA** is quoted in the diagram.
Sound pressure level L_{PA} at 1,5 m dist.

$$L_{PA} [\text{dB(A)}] = L_{wiA} - 14,5$$

Laufreddurchmesser	wheel diameter	D = 1258 mm
Schaufelzahl	number of blades	z = 20
Gewicht	weight	G = 85 kg
Drehzahl maximal	speed limit	n_{max} = 1400 1/min

Fan test laboratory AMCA 210/99 Fig.12, Test Chamber. Performance certified is for installation type D - Ducted inlet, Ducted outlet. Power Rating (kW) does not include transmission losses. Performance ratings do not include the effects of appurtenances (accessories).

The A-weighted sound ratings shown have been calculated per AMCA International Standard 301. Values shown are for inlet LwiA sound power levels for installation Type D: ducted inlet, ducted outlet. Ratings include the effects of duct end correction.

The test data were obtained in a laboratory accredited by AMCA for AMCA Standard 210 and 300 testing.

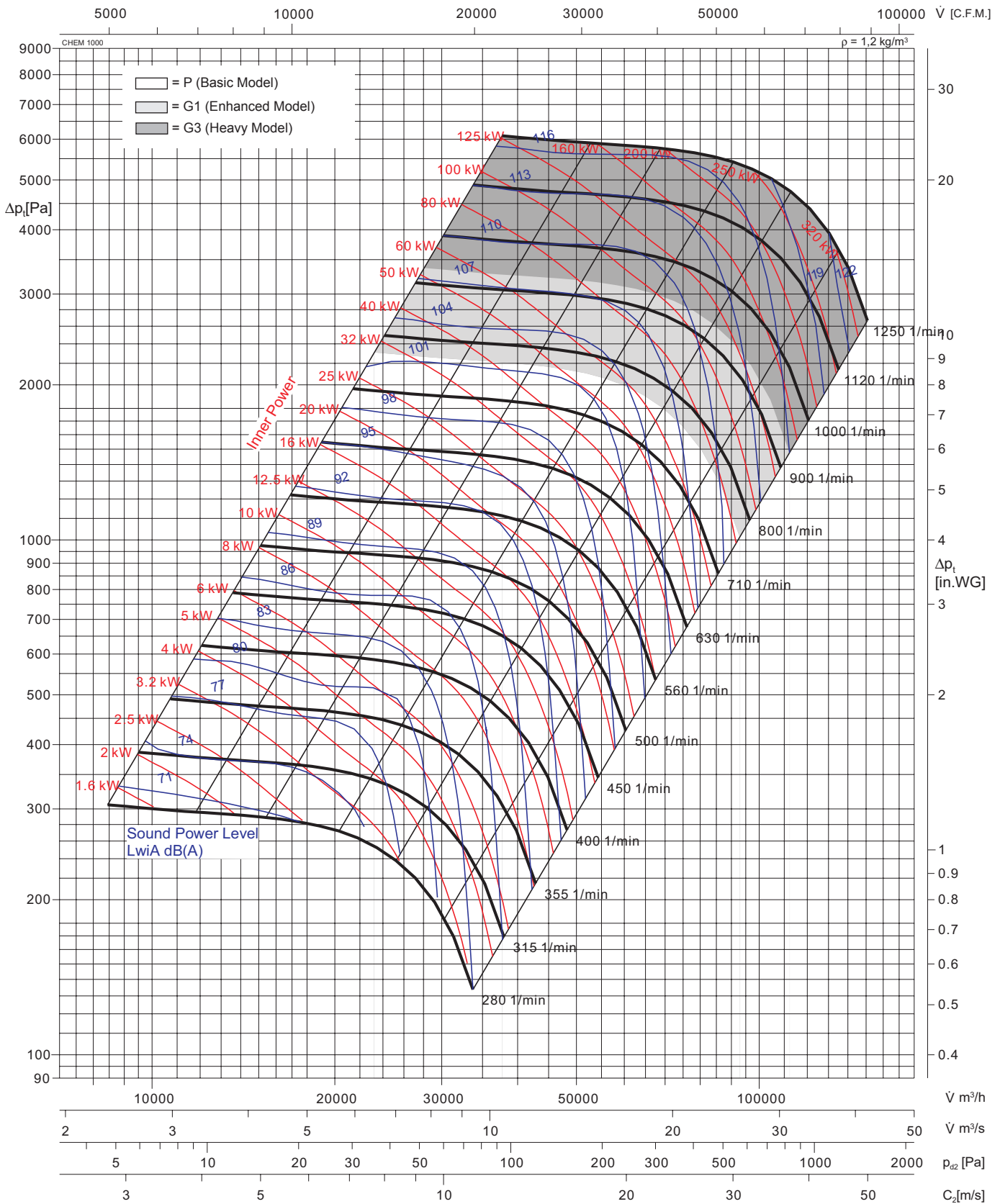

Im Kennfeld ist der A-bewertete Schalleistungspegel **LwiA** angegeben.
Schalldruckpegel L_{PA} in 1,5 m Entfernung

A-weighted sound power level **LwiA** is quoted in the diagram.
Sound pressure level L_{PA} at 1,5 m dist.

$$L_{PA} [\text{dB(A)}] = L_{wiA} - 14,5$$

Laufraddurchmesser	wheel diameter	D = 1429 mm
Schaufelzahl	number of blades	z = 20
Gewicht	weight	G = 100 kg
Drehzahl maximal	speed limit	n_{max} = 1250 1/min

Fan test laboratory AMCA 210/99 Fig.12, Test Chamber. Performance certified is for installation type D - Ducted inlet, Ducted outlet. Power Rating (kW) does not include transmission losses, Performance ratings do not include the effects of appurtenances (accessories).

The A-weighted sound ratings shown have been calculated per AMCA International Standard 301. Values shown are for inlet LwiA sound power levels for installation Type D: ducted inlet, ducted outlet. Ratings include the effects of duct end correction.

The test data were obtained in a laboratory accredited by AMCA for AMCA Standard 210 and 300 testing.

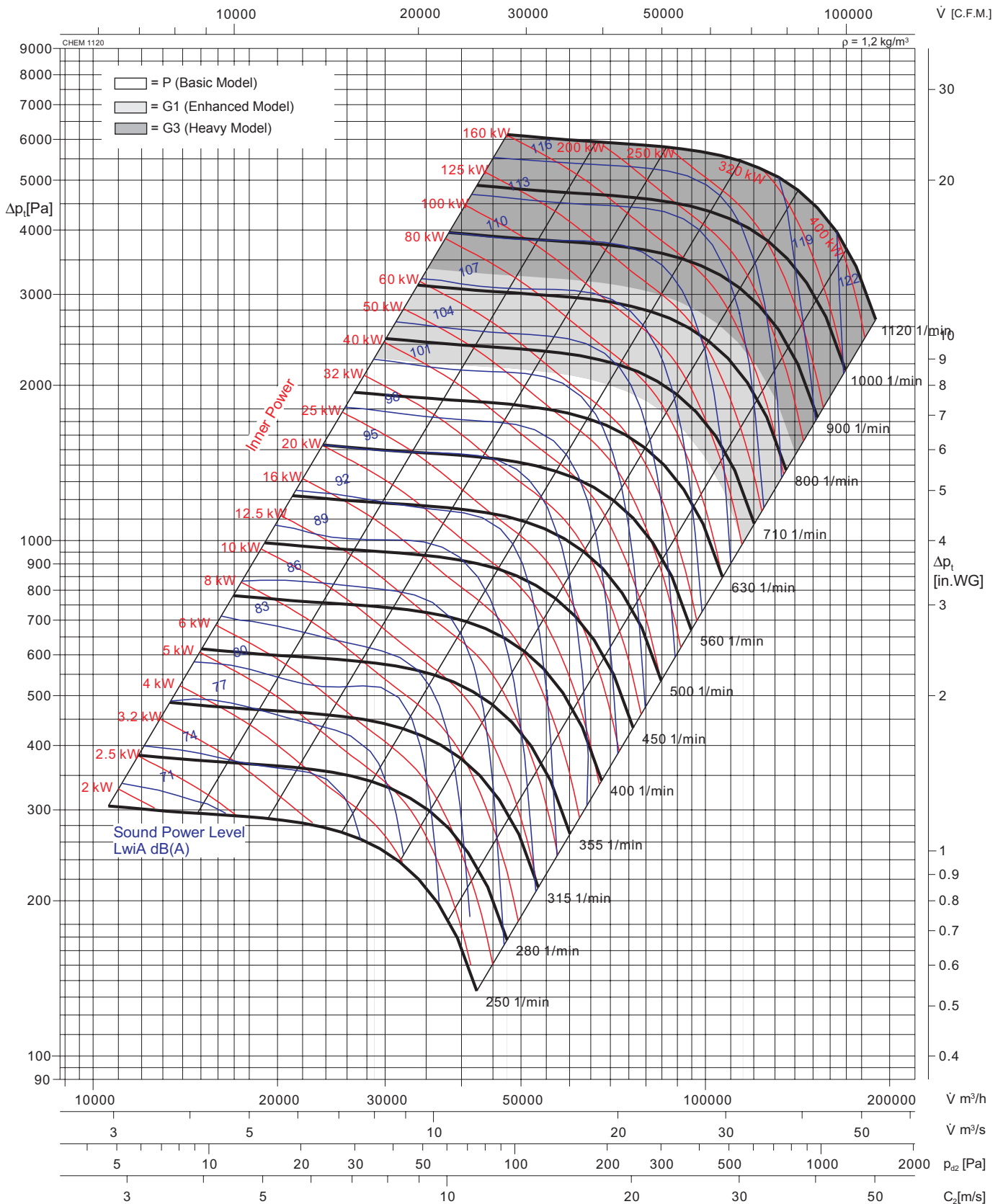

Im Kennfeld ist der A-bewertete Schalleistungspegel **LwiA** angegeben.
Schalldruckpegel L_{PA} in 1,5 m Entfernung

A-weighted sound power level **LwiA** is quoted in the diagram.
Sound pressure level L_{PA} at 1,5 m dist.

$$L_{PA} [\text{dB(A)}] = L_{wiA} - 14,5$$

Laufreddurchmesser	wheel diameter	D = 1600 mm
Schaufelzahl	number of blades	z = 20
Gewicht	weight	G = 130 kg
Drehzahl maximal	speed limit	n_{max} = 1120 1/min

Fan test laboratory AMCA 210/99 Fig.12, Test Chamber. Performance certified is for installation type D - Ducted inlet, Ducted outlet. Power Rating (kW) does not include transmission losses. Performance ratings do not include the effects of appurtenances (accessories).

The A-weighted sound ratings shown have been calculated per AMCA International Standard 301. Values shown are for inlet LwiA sound power levels for installation Type D: ducted inlet, ducted outlet. Ratings include the effects of duct end correction.

The test data were obtained in a laboratory accredited by AMCA for AMCA Standard 210 and 300 testing.

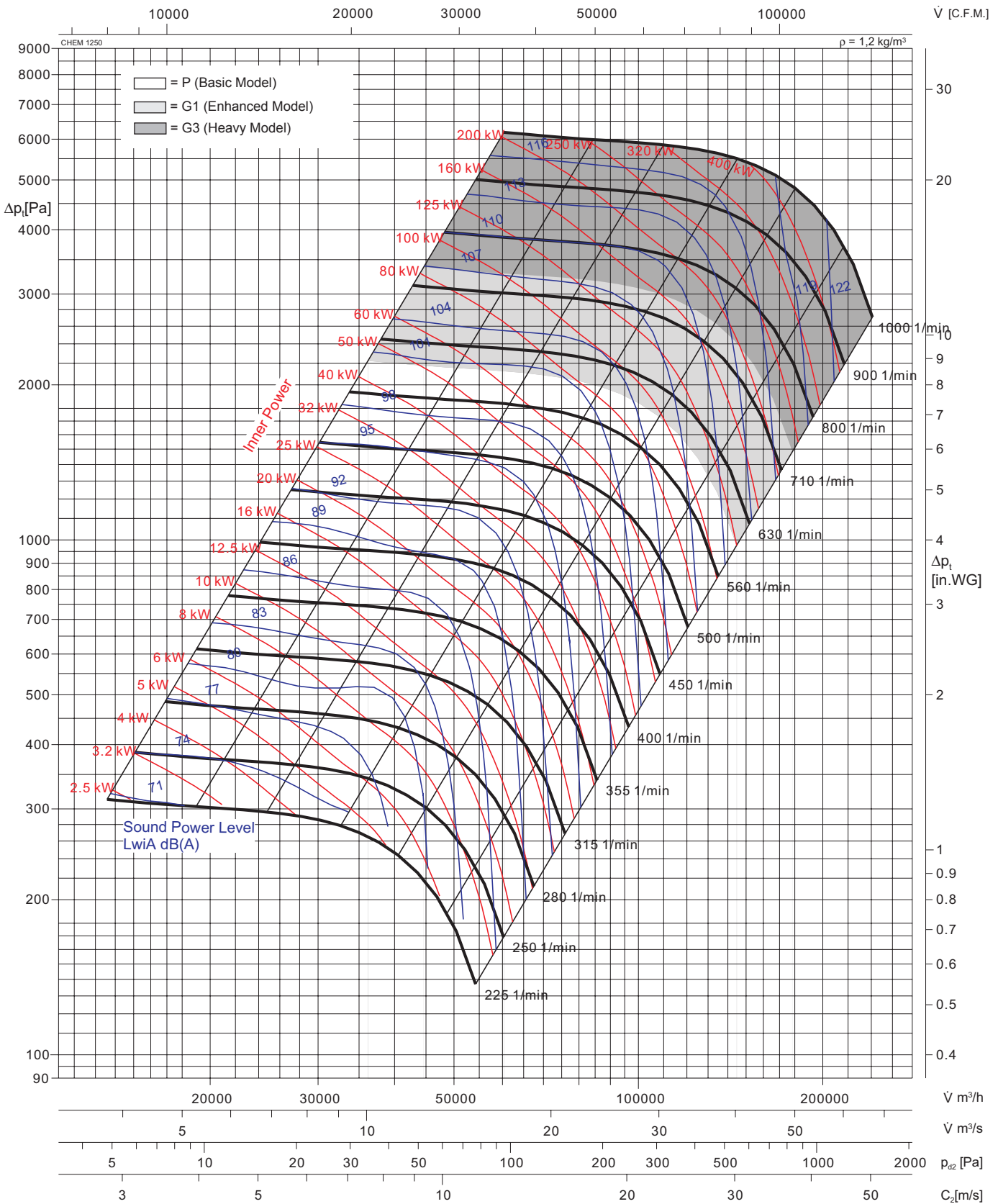

Im Kennfeld ist der A-bewertete Schalleistungspegel **L_{wiA}** angegeben.
Schalldruckpegel **L_{PA}** in 1,5 m Entfernung

A-weighted sound power level **L_{wiA}** is quoted in the diagram.
Sound pressure level **L_{PA}** at 1,5 m dist.

$$L_{PA} [\text{dB(A)}] = L_{wiA} - 14,5$$

Laufraddurchmesser	wheel diameter	D = 1800 mm
Schaufelzahl	number of blades	z = 20
Gewicht	weight	G = 160 kg
Drehzahl maximal	speed limit	n_{max} = 1000 1/min

Fan test laboratory AMCA 210/99 Fig.12, Test Chamber. Performance certified is for installation type D - Ducted inlet, Ducted outlet. Power Rating (kW) does not include transmission losses, Performance ratings do not include the effects of appurtenances (accessories).

The A-weighted sound ratings shown have been calculated per AMCA International Standard 301. Values shown are for inlet L_{wiA} sound power levels for installation Type D: ducted inlet, ducted outlet. Ratings include the effects of duct end correction.

The test data were obtained in a laboratory accredited by AMCA for AMCA Standard 210 and 300 testing.

Sound Information

Sound power levels

This term refers to the power which a source radiates as sound. Sound power levels are expressed in decibels with a reference level of 1 picoWatt. The sound power level of a source remains the same regardless of its environment and the distance to the listener.

If the sound power frequency spectrum is needed, for as follows: example, the design of sound attenuators, the A- rated sound power levels at particular octave band frequency L_{WA} can be calculated by subtracting the relative sound L_{wrel} .

$$L_{WA} = L_{wi} + L_{wrel}$$

Sound pressure level

These are pressure fluctuations generated by a source expressed in decibels with a reference level of 20 μ Pa. The sound pressure level varies with the distance of a sound source to the listener and its environment.

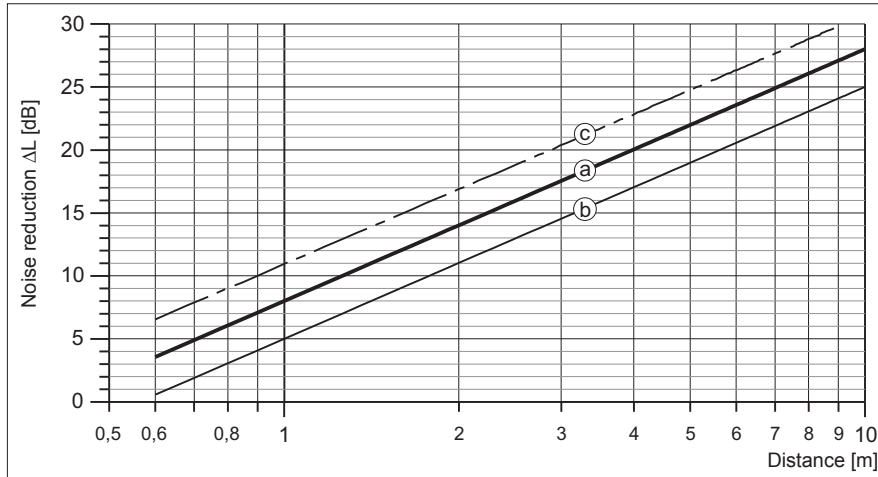

Sound level reduction half sphere

- a: without reflexion
- b: with reflexion
- c: full sphere without reflexion

Frequencies

Sound is split into different frequencies. Frequencies of human hearing range from about 20 cycles per second (Hz) to 20.000 cycles per second (Hz). For practical purposes, WOLTER publishes noise data in eight octave bands with the centre frequencies of (63,) 125, 250, 500, 1000, 2000, 4000 and 8000 Hz. Each fan has its own specific correction factor which is to be deducted from sound power according to the octave band.

A-weighted sound pressure level in dB (A)

The human ear is more sensitive to sound in some frequencies than in others. The A-weighting is an attempt to reflect this natural perception of sound. The A-weighting is a set of figures which are applied to the sound pressure levels. The levels in each of the octave bands are added logarithmically to give a single figure. The A-weighting over the octave band is as follows:

Table 1)

Frequency [Hz]	63	125	250	500	1000	2000	4000	8000
A-weighting [dB]	-25,5	-15,5	-8,5	-3	0	+1	+1	-1

Table 2)
Addition of sound levels

Difference between two sound levels [dB]	Add to the higher level [dB]
0 - 1	3
2 - 3	2
4 - 9	1
≥ 10	0

$$L_{\Sigma} = 10 \cdot \lg(10^{0,1 \cdot L_1} + 10^{0,1 \cdot L_2} + \dots + 10^{0,1 \cdot L_n})$$

where:

L_1 = sound level of a source 1

L_{Σ} = resulting summation sound level

Summation of several congeneric sound levels

$$L_{\Sigma} = L_1 + 10 \cdot \lg(z)$$

where:

z = number of sources

L_1 = sound level of a single source

L_{Σ} = resulting summation sound level

Relative Sound Power Frequency Spectrum (L_{wrel}) [dB]

Fan Model	Speed	63	125	250	500	1000	2000	4000	8000
Size	[RPM]	[Hz]	[Hz]	[Hz]	[Hz]	[Hz]	[Hz]	[Hz]	[Hz]
75	1250 ~ 2250	-4	-4	-13	-8	-16	-28	-34	-39
	2500 ~ 5800	-8	-4	-5	-14	-9	-18	-30	-36
90	1250 ~ 2250	-4	-4	-13	-8	-16	-28	-34	-39
	2500 ~ 5800	-8	-4	-5	-14	-9	-18	-30	-36
110	1250 ~ 2250	-4	-4	-13	-8	-16	-28	-34	-39
	2500 ~ 5800	-8	-4	-5	-14	-9	-18	-30	-36
125	1250 ~ 2250	-4	-4	-13	-8	-16	-28	-34	-39
	2500 ~ 5730	-8	-4	-5	-14	-9	-18	-30	-36
160	900 ~ 2000	-3	-6	-14	-7	-23	-30	-36	-40
	2250 ~ 4580	-7	-4	-7	-15	-8	-23	-31	-37
180	900 ~ 1800	-2	-7	-12	-8	-24	-30	-36	-40
	2000 ~ 4090	-6	-4	-9	-13	-9	-25	-32	-38
200	1120 ~ 2000	-3	-6	-14	-7	-23	-30	-36	-40
	2250 ~ 4800	-7	-4	-7	-15	-8	-23	-31	-37
250	1000 ~ 1800	-3	-6	-14	-7	-23	-30	-36	-40
	2000 ~ 4500	-7	-4	-7	-15	-8	-23	-31	-37
315	900 ~ 1600	-2	-9	-10	-9	-25	-31	-36	-40
	1800 ~ 3650	-5	-3	-10	-12	-11	-26	-32	-38
400	800 ~ 1800	-4	-4	-8	-16	-19	-24	-30	-33
	2000 ~ 3300	-5	-4	-7	-7	-17	-20	-25	-30
450	630 ~ 1600	-4	-4	-8	-16	-19	-24	-30	-33
	1800 ~ 2800	-4	-5	-6	-10	-18	-21	-26	-31
500	560 ~ 1250	-4	-4	-9	-16	-19	-25	-30	-34
	1400 ~ 2500	-4	-6	-6	-14	-19	-23	-29	-33
560	500 ~ 1120	-4	-3	-11	-16	-20	-26	-30	-34
	1250 ~ 2200	-4	-6	-6	-13	-19	-22	-28	-32
630	450 ~ 1000	-4	-3	-12	-16	-20	-26	-30	-34
	1120 ~ 2200	-4	-6	-6	-14	-19	-23	-29	-33
710	400 ~ 800	-2	-6	-14	-17	-22	-27	-31	-36
	900 ~ 1800	-4	-4	-8	-16	-19	-24	-30	-33
800	355 ~ 710	-1	-7	-14	-17	-23	-28	-31	-37
	800 ~ 1600	-4	-4	-9	-16	-19	-25	-30	-34
900	315 ~ 630	-1	-8	-14	-17	-23	-28	-32	-38
	710 ~ 1400	-4	-3	-11	-16	-20	-26	-30	-34
1000	280 ~ 560	-1	-8	-14	-17	-23	-28	-32	-37
	630 ~ 1250	-4	-3	-12	-16	-20	-26	-30	-34
1120	250 ~ 500	-1	-10	-14	-18	-24	-28	-32	-40
	560 ~ 1120	-3	-4	-13	-16	-21	-27	-31	-35
1250	225 ~ 450	-1	-9	-14	-18	-24	-28	-32	-39
	500 ~ 1000	-3	-4	-13	-16	-21	-27	-31	-35

* Sound power frequency spectrum calculated with this L_{wrel} are not licensed by AMCA.

Abmessungen

Dimension



CHEM 75R - 110FC PP

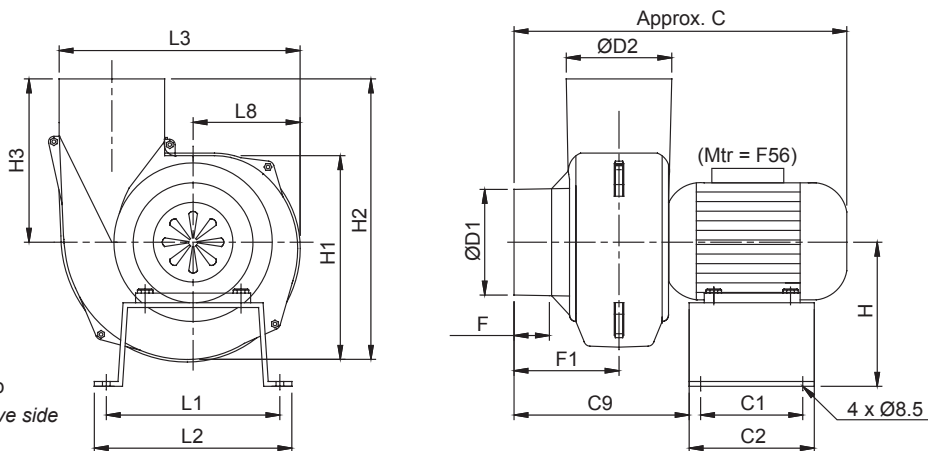

Drehrichtung von Antriebsseite aus gesehen
 G = Gewicht des nackten Ventilators ohne Antrieb
 The direction of rotation is as viewed from the drive side
 G = Barefan weight approximately

Baugröße size	C [mm]	C1 [mm]	C2 [mm]	C9 [mm]	D1 [mm]	D2 [mm]	F [mm]	F1 [mm]
75R	283	107	131	125	75	75	35	84
90R	347	107	131	183	90	90	37	109
90FC	347	107	131	183	90	90	37	109
110FC	347	107	131	183	110	110	37	109

Baugröße size	H [mm]	H1 [mm]	H2 [mm]	H3 [mm]	L1 [mm]	L2 [mm]	L3 [mm]	L8 [mm]
75R	158	170	198	100	181	206	200	88
90R	158	212	292	170	181	206	251	112
90FC	158	212	292	170	181	206	251	112
110FC	158	212	292	170	181	206	251	112

Maß- und Konstruktionsänderungen, dem technischen Fortschritt dienend, bleiben uns vorbehalten.
 We reserve the right to alter measurements without notice in case of technical improvements

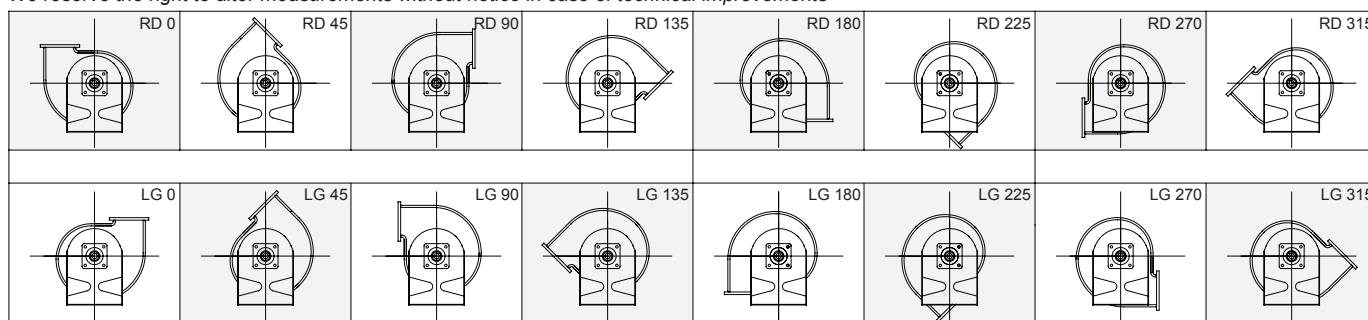

Abmessungen

Dimension



CHEM 125-400 PP

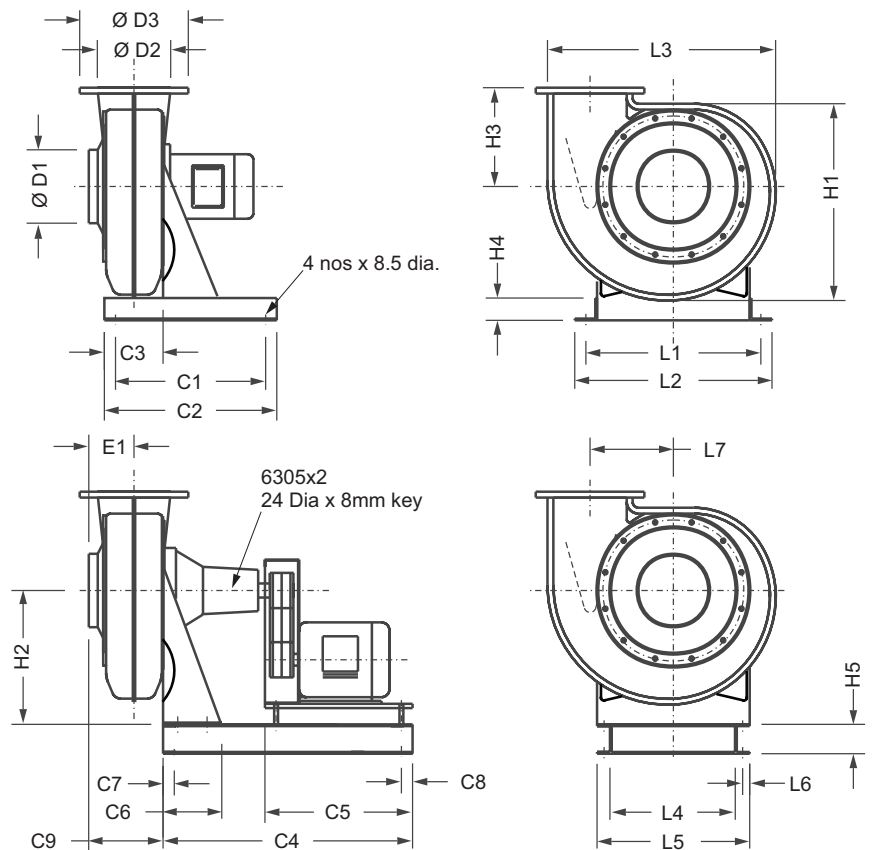

Drehrichtung von Antriebsseite aus gesehen

G = Gewicht des nackten Ventilators ohne Antrieb

The direction of rotation is as viewed from the drive side

G = Barefan weight approximatly

Größe	D1	D2	D3	C1	C2	C3	C4	C5	C6	C7	C8	C9	E1	H1
size	(mm)	(mm)	(mm)	(mm)	(mm)	(mm)	(mm)	(mm)	(mm)	(mm)	(mm)	(mm)	(mm)	(mm)
125	125	125	185	256	294	100	425	320	100	19	19	127	95	351
160	160	160	220	282	320	100	475	320	128	19	19	162	116	445
180	180	180	240	312	350	100	550	320	150	19	19	206	132	503
200	200	200	260	312	350	100	550	320	150	25	25	203	124	518
250	250	250	310	300	350	100	600	450	150	25	25	231	140	621
315	315	315	375	350	400	125	650	450	150	25	25	281	165	780
400	400	400	480	400	450	150	650	450	150	25	25	321	201	898
Größe	H2a	H2b	H3	H4	H5	L1	L2	L3	L4	L5	L6	L7	G	
size	(mm)	(mm)	(mm)	(mm)	(mm)	(mm)	(mm)	(mm)	(mm)	(mm)	(mm)	(mm)	(kg)	
125	228	308	170	20	50	298	336	400	210	260	12	142	18	
160	291	396	217	20	50	370	408	504	282	332	12	182	32	
180	327	440	250	20	50	411	449	571	308	373	19	234	38	
200	364	500	271	20	50	453	491	590	345	415	12	204	43	
250	454	633	320	30	80	568	618	723	442	518	19	261	52	
315	530	720	412	30	80	659	709	910	533	609	19	332	78	
400	557	750	458	30	80	721	771	1043	595	671	19	356	108	

Maß- und Konstruktionsänderungen, dem technischen Fortschritt dienend, bleiben uns vorbehalten.

We reserve the right to alter measurements without notice in case of technical improvements

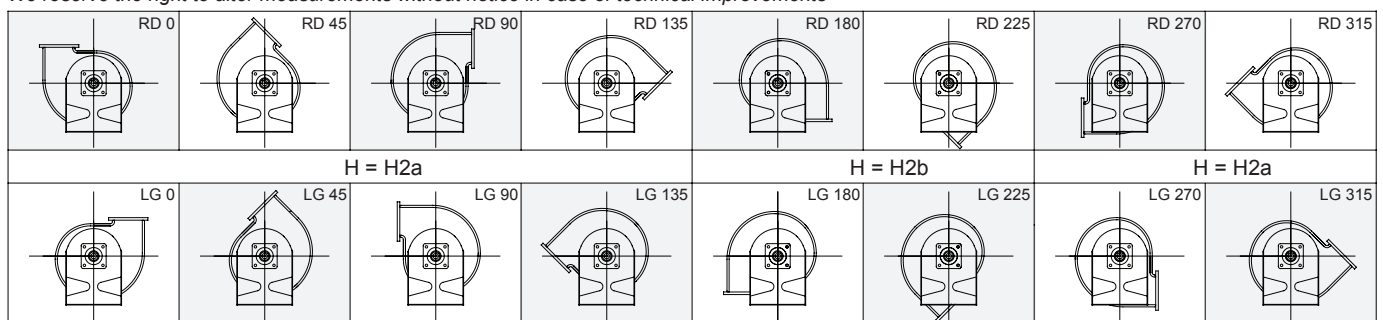

Abmessungen

Dimension



CHEM 200-400 GRP

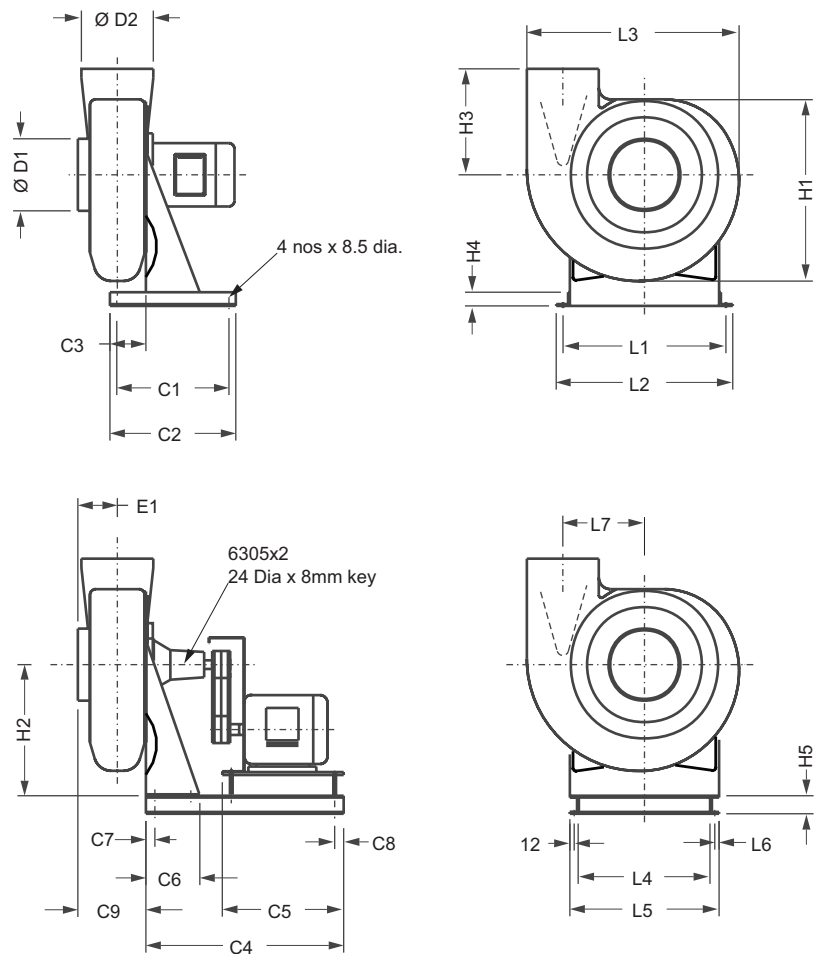

Drehrichtung von Antriebsseite aus gesehen
 G = Gewicht des nackten Ventilators ohne Antrieb
 The direction of rotation is as viewed from the drive side
 G = Barefan weight approximatly

Größe	D1	D2	D3	C1	C2	C3	C4	C5	C6	C7	C8	C9	E1	H1
size	(mm)	(mm)	(mm)	(mm)	(mm)	(mm)	(mm)	(mm)	(mm)	(mm)	(mm)	(mm)	(mm)	(mm)
200	192	193	na	312	350	100	550	320	150	25	25	189	110	505
250	240	242	na	300	350	100	600	450	150	25	25	210	121	658
315	305	306	na	350	400	125	650	450	150	25	25	245	142	795
400	386	390	na	400	450	150	650	450	150	25	25	280	165	858

Größe	H2a	H2b	H3	H4	H5	L1	L2	L3	L4	L5	L6	L7	G
size	(mm)	(mm)	(mm)	(mm)	(mm)	(mm)	(mm)	(mm)	(mm)	(mm)	(mm)	(mm)	(kg)
200	364	500	294	38	50	453	491	590	345	410	19	227	43
250	454	633	337	50	80	568	618	722	442	518	19	269	52
315	530	720	464	50	80	659	709	930	533	609	19	358	78
400	557	750	510	50	80	721	771	1003	595	671	19	357	108

Maß- und Konstruktionsänderungen, dem technischen Fortschritt dienend, bleiben uns vorbehalten.
 We reserve the right to alter measurements without notice in case of technical improvements

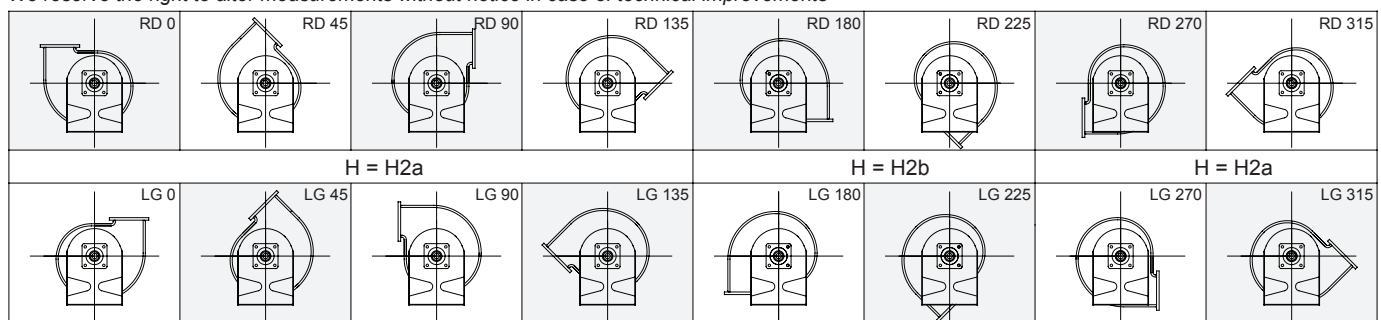

Abmessungen

Dimension



CHEM 450-710 GRP

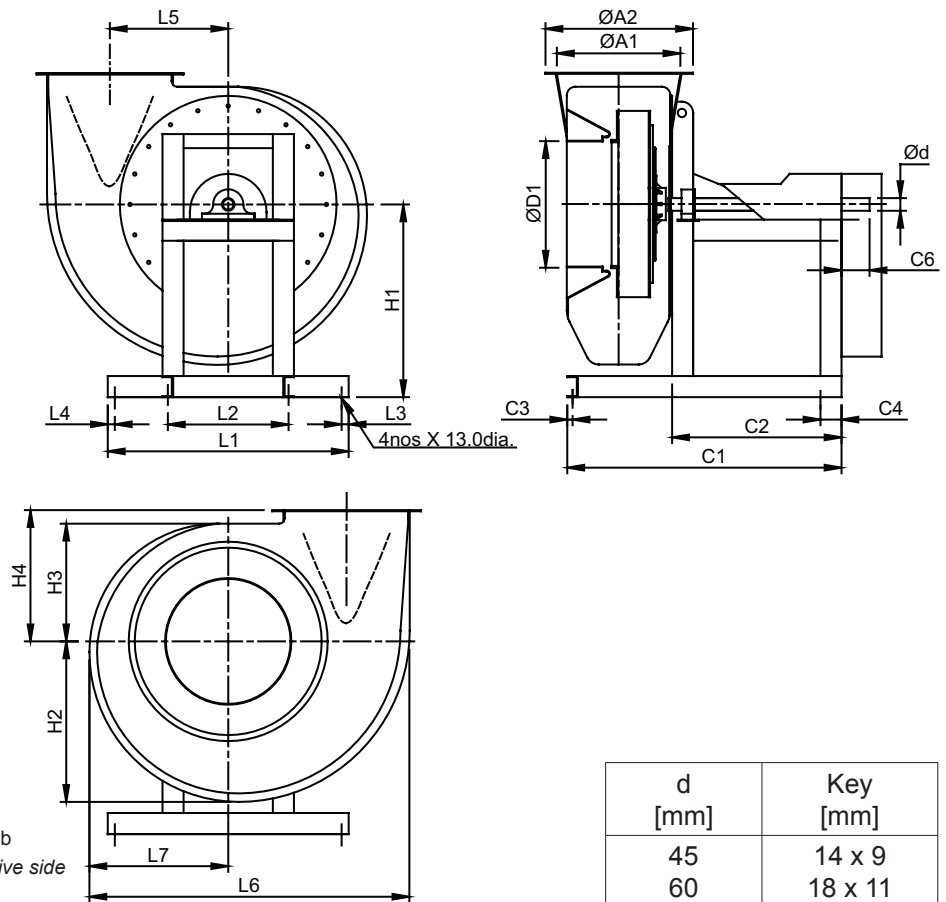

Drehrichtung von Antriebsseite aus gesehen

G = Gewicht des nackten Ventilators ohne Antrieb

The direction of rotation is as viewed from the drive side

G = Barefan weight approximatly

d [mm]	Key [mm]
45	14 x 9
60	18 x 11

Größe	A1	A2	B1	B2	C1	C2	C3	C4	C5	C6	D1	d	H1a	H1b
size	[mm]	[mm]	[mm]	[mm]	[mm]	[mm]	[mm]	[mm]	[mm]	[mm]	[mm]	[mm]	[mm]	[mm]
450	457	557	-	-	977	604	19	75	-	100	450	45	685	598
500	517	617	-	-	1013	604	19	75	-	100	500	45	783	633
560	580	680	-	-	1058	604	19	75	-	125	560	45	870	709
630	651	751	-	-	1184	677	19	75	-	125	630	60	939	775
710	731	831	-	-	1332	761	19	75	-	125	710	60	1030	900
Größe	H1c	H1d	H1e	H2	H3	H4	L1	L2	L3	L4	L5	L6	L7	G
size	[mm]	[mm]	[mm]	[mm]	[mm]	[mm]	[mm]	[mm]	[mm]	[mm]	[mm]	[mm]	[mm]	(kg)
450	TBA	800	700	571	418	467	858	430	25	25	448	1210	494	156
500	TBA	911	786	634	465	518	970	448	25	25	570	1360	549	188
560	TBA	1005	879	710	521	580	1090	448	25	25	630	1520	615	228
630	TBA	1128	950	799	586	653	1222	507	25	25	705	1720	692	248
710	TBA	1250	1110	900	660	736	1273	573	25	25	795	1930	780	280

Maß- und Konstruktionsänderungen, dem technischen Fortschritt dienend, bleiben uns vorbehalten.

We reserve the right to alter measurements without notice in case of technical improvements

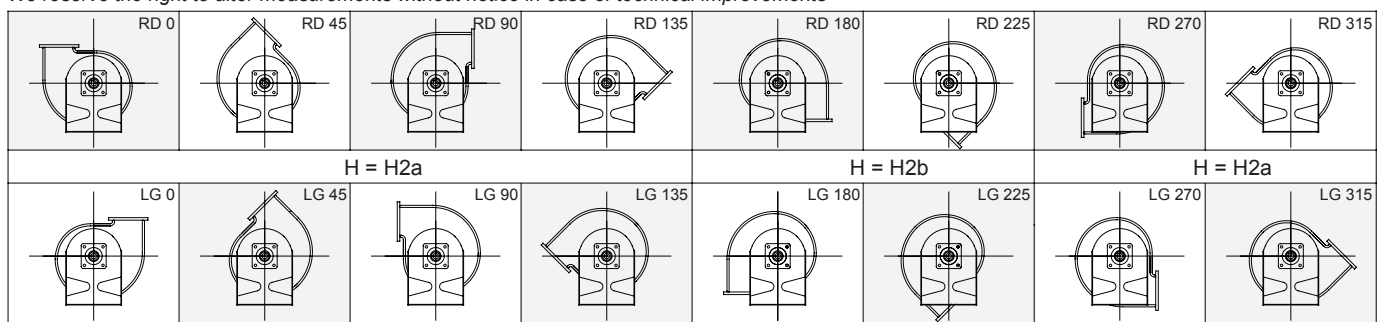

Abmessungen

Dimension



CHEM 800-1250 GRP

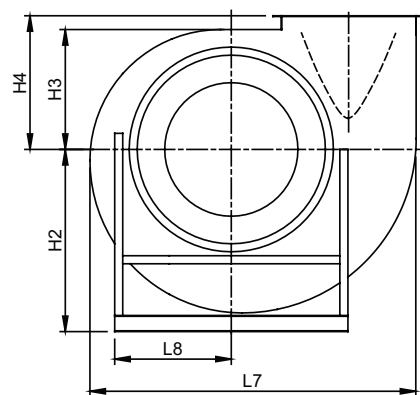
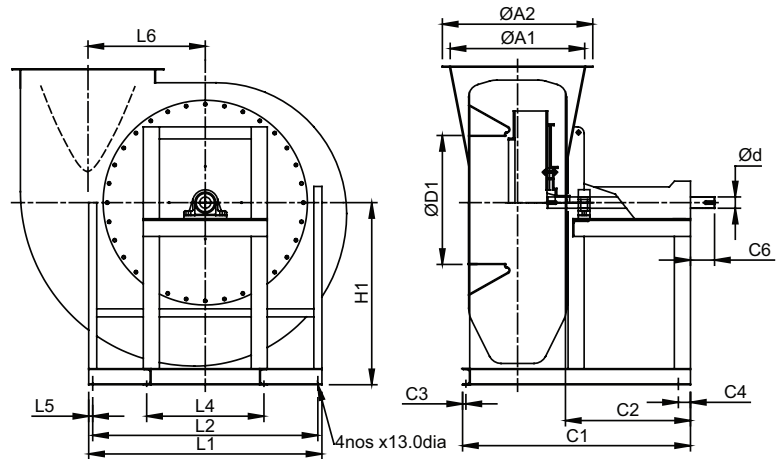

Drehrichtung von Antriebsseite aus gesehen
 G = Gewicht des nackten Ventilators ohne Antrieb
 The direction of rotation is as viewed from the drive side
 G = Barefan weight approximatly

d [mm]	Key [mm]
70	20 x 12
80	22 x 14

Größe	A1	A2	B1	B2	C1	C2	C3	C4	C5	C6	D1	d	H1a	H1b
size	[mm]	[mm]	[mm]	[mm]	[mm]	[mm]	[mm]	[mm]	[mm]	[mm]	[mm]	[mm]	[mm]	[mm]
800	790	900	-	-	1417	761	25	75	-	160	800	70	1130	1000
900	875	995	-	-	1756	1000	25	75	-	160	900	70	1278	1105
1000	988	1130	-	-	1833	1000	25	75	-	160	1000	70	1375	1200
1120	1107	1256	-	-	1896	1000	25	75	-	200	1120	80	1550	1350
1250	1242	1390	-	-	1991	1000	25	75	-	200	1250	80	1700	1500
Größe	H1c	H1d	H1e	H2	H3	H4	L1	L2	L4	L5	L6	L7	L8	G
size	[mm]	[mm]	[mm]	[mm]	[mm]	[mm]	[mm]	[mm]	[mm]	[mm]	[mm]	[mm]	[mm]	(kg)
800	TBA	1280	1230	1014	744	829	1450	1400	721	25	729	2029	879	420
900	TBA	1428	1362	1141	837	933	1632	1582	818	25	821	2282	989	500
1000	TBA	1560	1500	1268	930	1037	1813	1763	914	25	912	2536	1099	625
1120	TBA	1760	1600	1420	1041	1161	2030	1980	1030	25	1021	2840	1231	722
1250	TBA	1935	1800	1585	1162	1296	2100	2050	1140	25	1140	3170	1373	859

Maß- und Konstruktionsänderungen, dem technischen Fortschritt dienend, bleiben uns vorbehalten.
 We reserve the right to alter measurements without notice in case of technical improvements

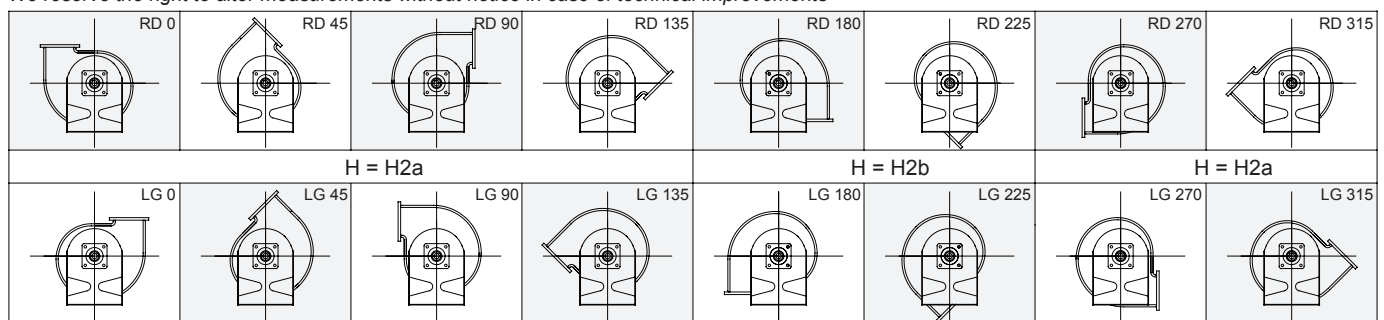

Transition Outlet

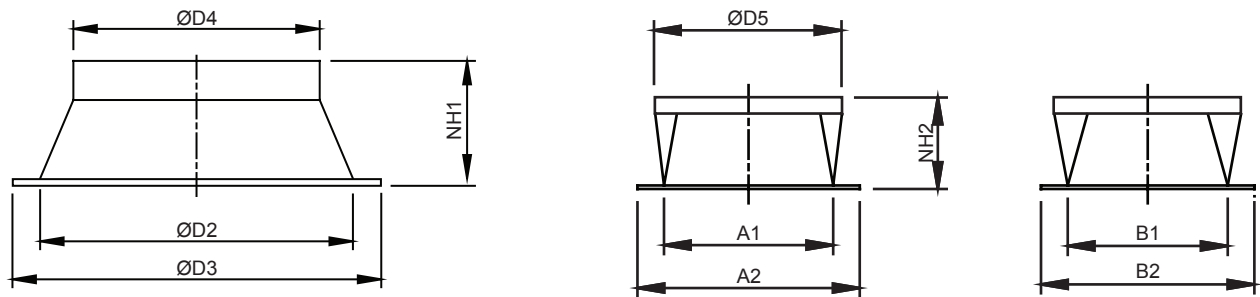

Baugröße	A1	A2	B1	B2	D2	D3	D4	D5	NH1	NH2
size	[mm]	[mm]	[mm]	[mm]	[mm]	[mm]	[mm]	[mm]	[mm]	[mm]
125	-	-	-	-	125	185	110	-	100	-
160	-	-	-	-	160	220	125	-	100	-
180	-	-	-	-	180	240	160	-	120	-
200	-	-	-	-	200	260	180	-	120	-
250	-	-	-	-	250	310	200	-	150	-
315	-	-	-	-	315	375	250	-	150	-
400	-	-	-	-	400	480	315	-	200	-
450	440	530	360	450	457	557	400	449	250	252
500	490	590	400	500	517	617	450	500	270	274
560	550	650	450	550	580	680	500	561	300	302
630	620	720	505	605	651	751	560	631	330	333
710	710	810	580	680	731	831	630	724	370	375
800	830	940	590	700	790	900	710	802	410	410
900	945	1065	665	785	875	995	800	888	450	450
1000	1034	1176	748	886	988	1130	900	984	490	492
1120	1176	1325	838	992	1107	1256	1000	1129	550	557
1250	1291	1439	917	1065	1242	1390	1120	1228	600	601

Maß- und Konstruktionsänderungen, dem technischen Fortschritt dienend, bleiben uns vorbehalten.

We reserve the right to alter measurements without notice in case of technical improvements

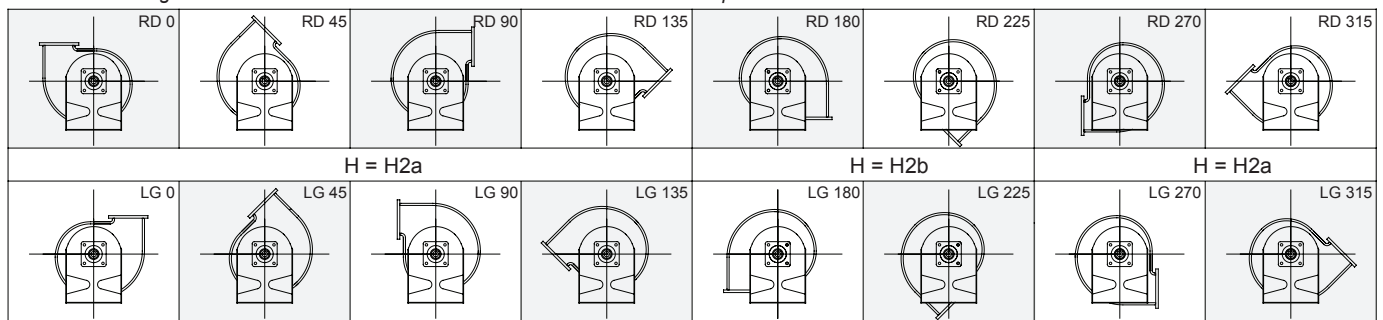

Abmessungen

Dimension



Fume Jet Nozzles (S Type: SE 30)

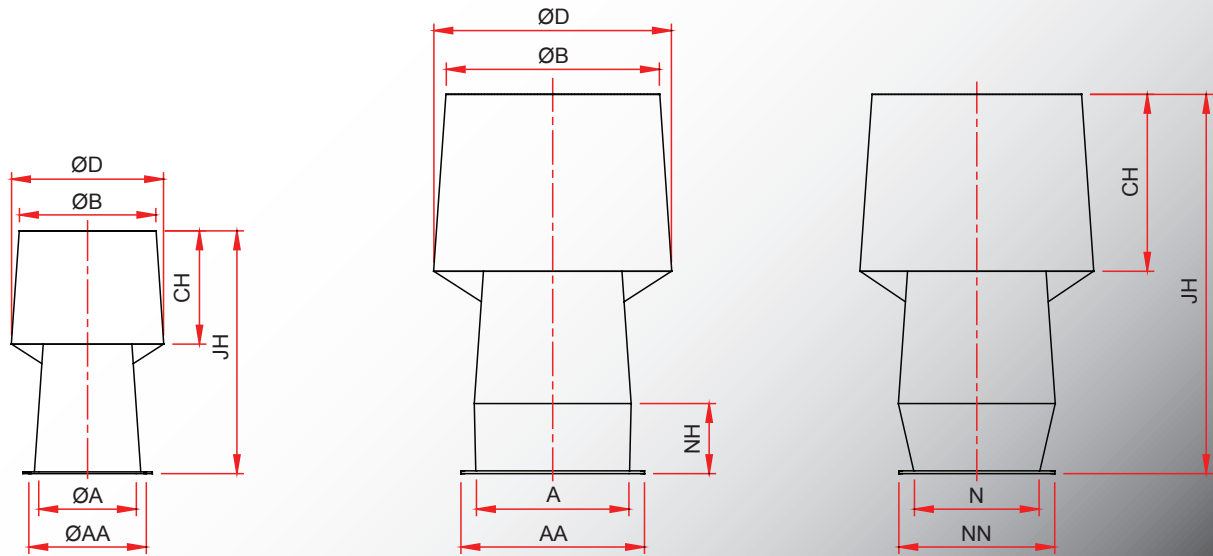

Fan model	AA	NN	A	N	B	D	CH	NH	JH	Fan Height
Size	[mm]	[mm]	[mm]	[mm]	[mm]	[mm]	[mm]	[mm]	[mm]	[mm]
125	185	-	121	-	166	185	137	-	240	448
160	220	-	154	-	211	235	175	-	305	559
180	240	-	174	-	238	266	198	-	345	636
200	260	-	194	-	266	296	220	-	384	667
250	310	-	245	-	335	374	278	-	485	854
315	375	-	309	-	423	472	351	-	612	1018
400	480	-	392	-	537	599	445	-	777	1147
450	530	450	440	360	615	686	510	202	1091	1152
500	590	500	490	400	684	763	568	224	1214	1301
560	650	550	550	450	768	858	638	252	1364	1451
630	720	605	620	505	864	965	717	283	1534	1595
710	810	680	710	580	991	1106	823	325	1760	1770
800	940	700	830	590	1091	1225	911	360	1948	1960
900	1065	785	945	665	1216	1357	1009	399	2159	2200
1000	1176	886	1034	748	1348	1504	1118	442	2392	2420
1120	1325	992	1176	838	1546	1725	1283	507	2744	2700
1250	1439	1065	1291	917	1681	1876	1395	551	2984	3000

Maß- und Konstruktionsänderungen, dem technischen Fortschritt dienend, bleiben uns vorbehalten.

We reserve the right to alter measurements without notice in case of technical improvements

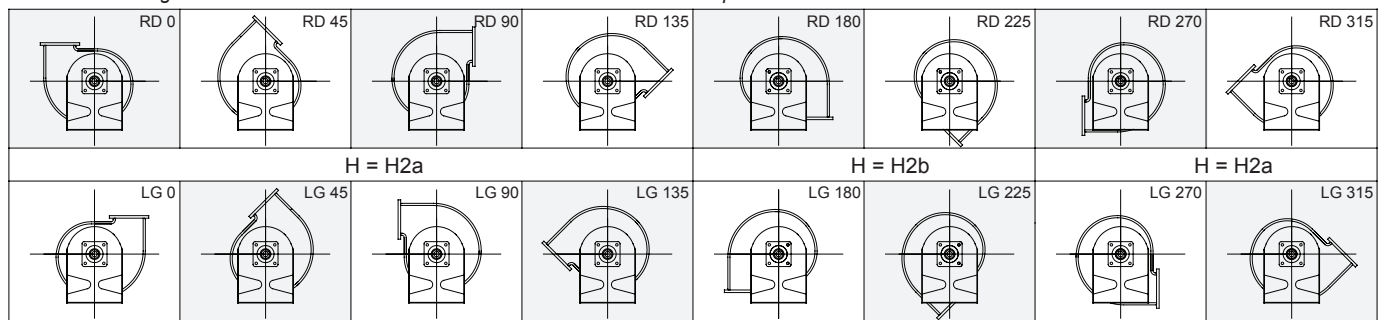

Abmessungen

Dimension



Fume Jet Nozzles (H Type: HE 40)

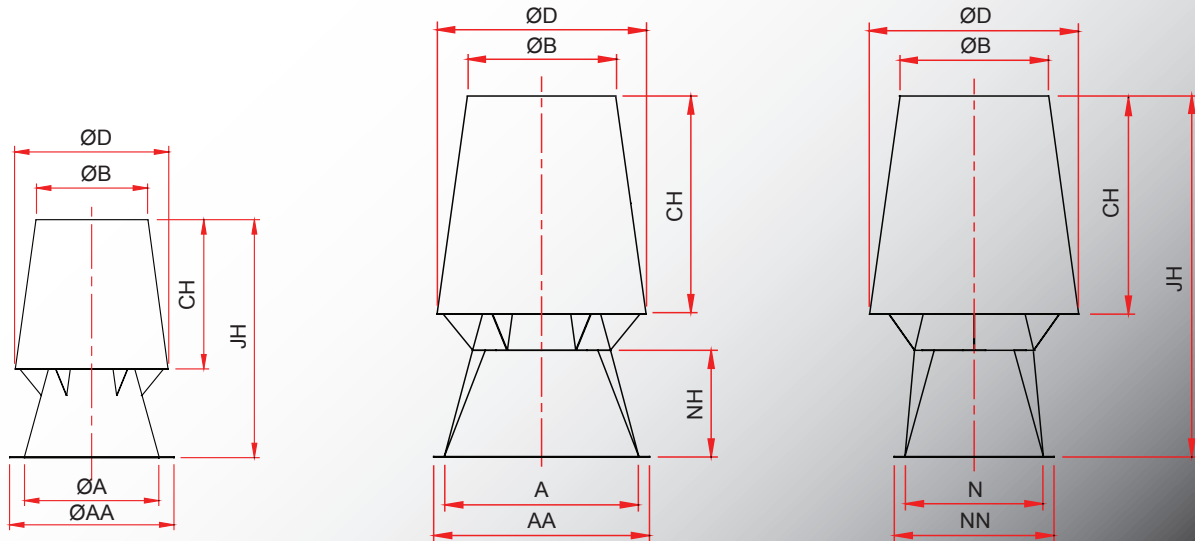

Fan model	AA	NN	A	N	B	D	CH	NH	JH	Fan Height
Size	[mm]	[mm]	[mm]	[mm]	[mm]	[mm]	[mm]	[mm]	[mm]	[mm]
125	185	-	121	-	99	137	138	-	217	448
160	220	-	154	-	125	174	176	-	276	559
180	240	-	174	-	142	197	198	-	312	636
200	260	-	194	-	158	219	221	-	348	667
250	310	-	245	-	200	277	279	-	440	854
315	375	-	309	-	252	349	352	-	554	1018
400	480	-	392	-	319	443	447	-	703	1147
450	530	450	440	360	366	508	512	260	860	1152
500	590	500	490	400	407	565	569	289	957	1301
560	650	550	550	450	457	635	640	325	1075	1451
630	720	605	620	505	514	714	720	366	1210	1595
710	810	680	710	580	590	819	825	419	1387	1770
800	940	700	830	590	653	906	914	464	1536	1960
900	1065	785	945	665	724	1004	1013	514	1702	2200
1000	1176	886	1034	748	802	1113	1122	570	1886	2420
1120	1325	992	1176	838	920	1276	1287	654	2163	2700
1250	1439	1065	1291	917	1000	1388	1400	711	2352	3000

Maß- und Konstruktionsänderungen, dem technischen Fortschritt dienend, bleiben uns vorbehalten.

We reserve the right to alter measurements without notice in case of technical improvements

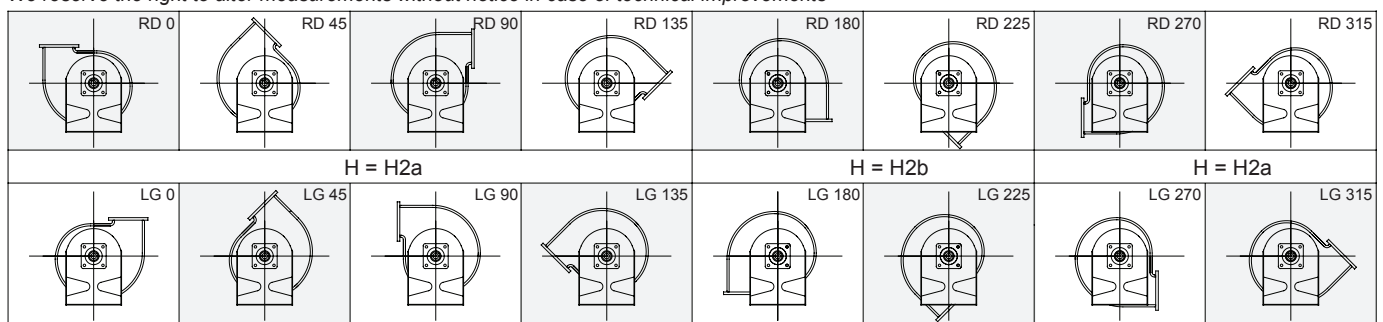

Abmessungen

Dimension



Fume Jet Nozzles (H Type: HDE 80)

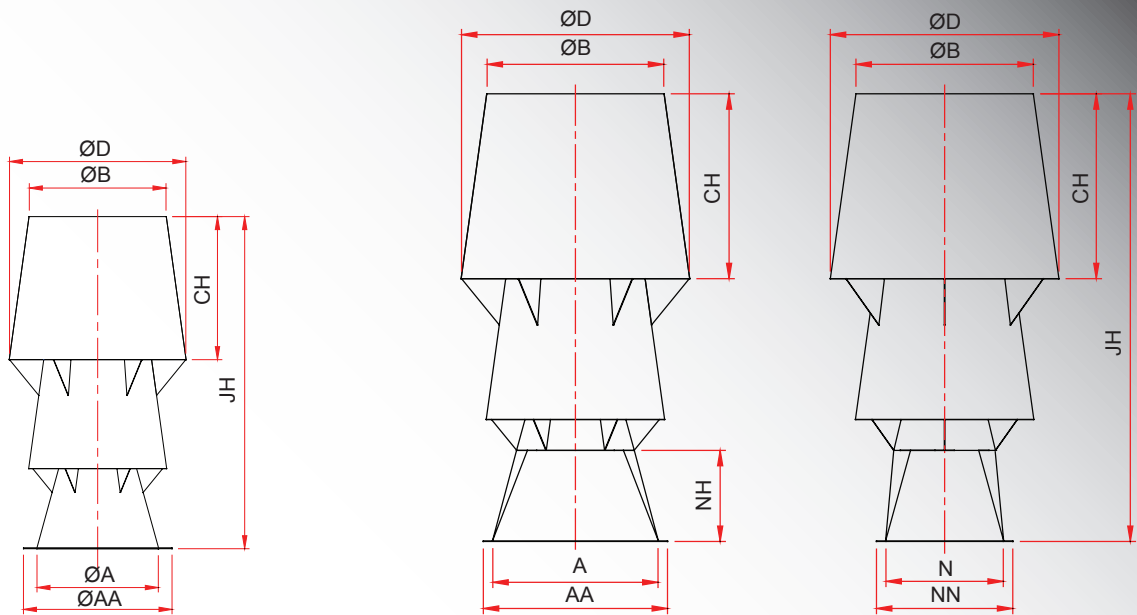

Fan model	AA	NN	A	N	B	D	CH	NH	JH	Fan Height
Size	[mm]	[mm]	[mm]	[mm]	[mm]	[mm]	[mm]	[mm]	[mm]	[mm]
125	185	-	121	-	175	136	142	-	330	448
160	220	-	154	-	223	173	181	-	420	559
180	240	-	174	-	252	196	205	-	474	636
200	260	-	194	-	281	218	228	-	529	667
250	310	-	245	-	355	275	288	-	668	854
315	375	-	309	-	448	347	363	-	842	1018
400	480	-	392	-	568	441	461	-	1068	1147
450	530	450	440	360	651	505	528	260	1278	1152
500	590	500	490	400	724	562	587	289	1422	1301
560	650	550	550	450	814	631	660	325	1598	1451
630	720	605	620	505	915	710	742	366	1797	1595
710	810	680	710	580	1050	814	851	419	2061	1770
800	940	700	830	590	1162	901	942	464	2282	1960
900	1065	785	945	665	1288	999	1044	514	2529	2200
1000	1176	886	1034	748	1427	1107	1157	570	2802	2420
1120	1325	992	1176	838	1637	1269	1327	654	3214	2700
1250	1439	1065	1291	917	1780	1380	1443	711	3498	3000

Maß- und Konstruktionsänderungen, dem technischen Fortschritt dienend, bleiben uns vorbehalten.

We reserve the right to alter measurements without notice in case of technical improvements

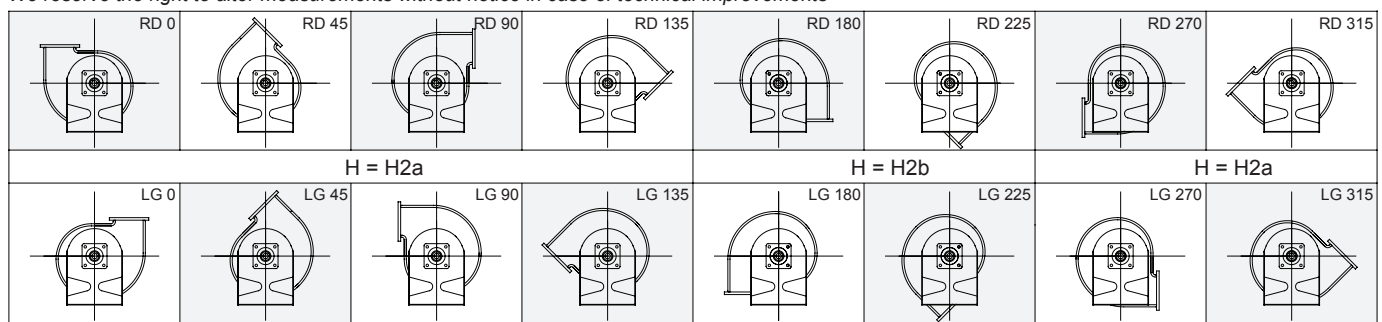

Auf-und Einbau

Assembly and mounting



CHEM 75 to 110 DD

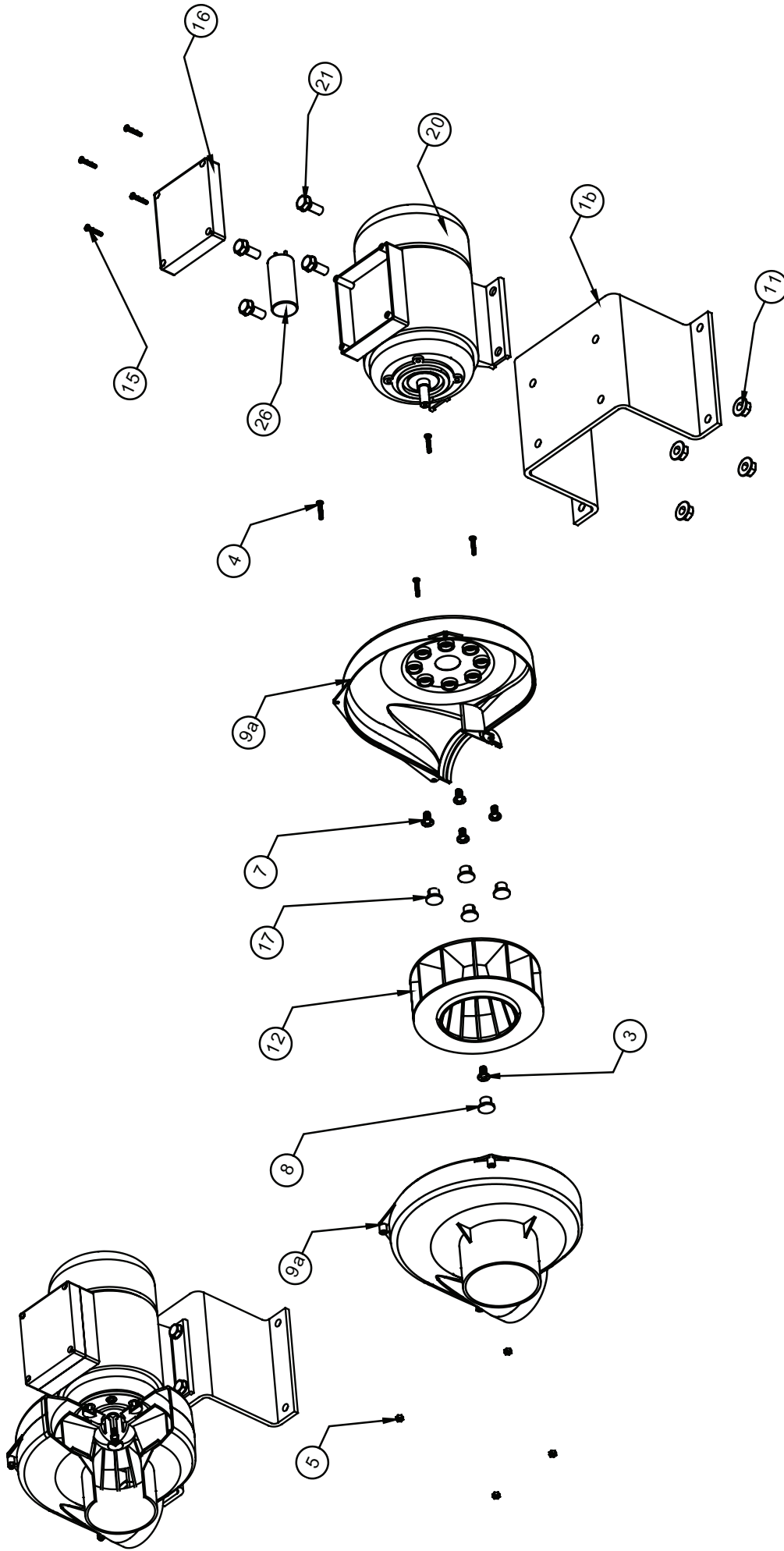

Part Nos	Description	Part Nos	Description
01-1b	Steel stand	01-12	Fan impeller
01-3	Impeller screw	01-15	T-box cover mounting screw
01-4	Fan casing bolts	01-16	T-box cover
01-5	Fan casing nut	01-17	Fan casing plug
01-7	Fan casing screw	01-20	Electric motor
01-8	Impeller plug	01-21	Steel stand screw and wash
01-9a	Fan Casing (PP type)	01-26	Capacitor
01-11	Steel stand nut		

Auf- und Einbau Assembly and mounting

CHEM 125 to 200 DD

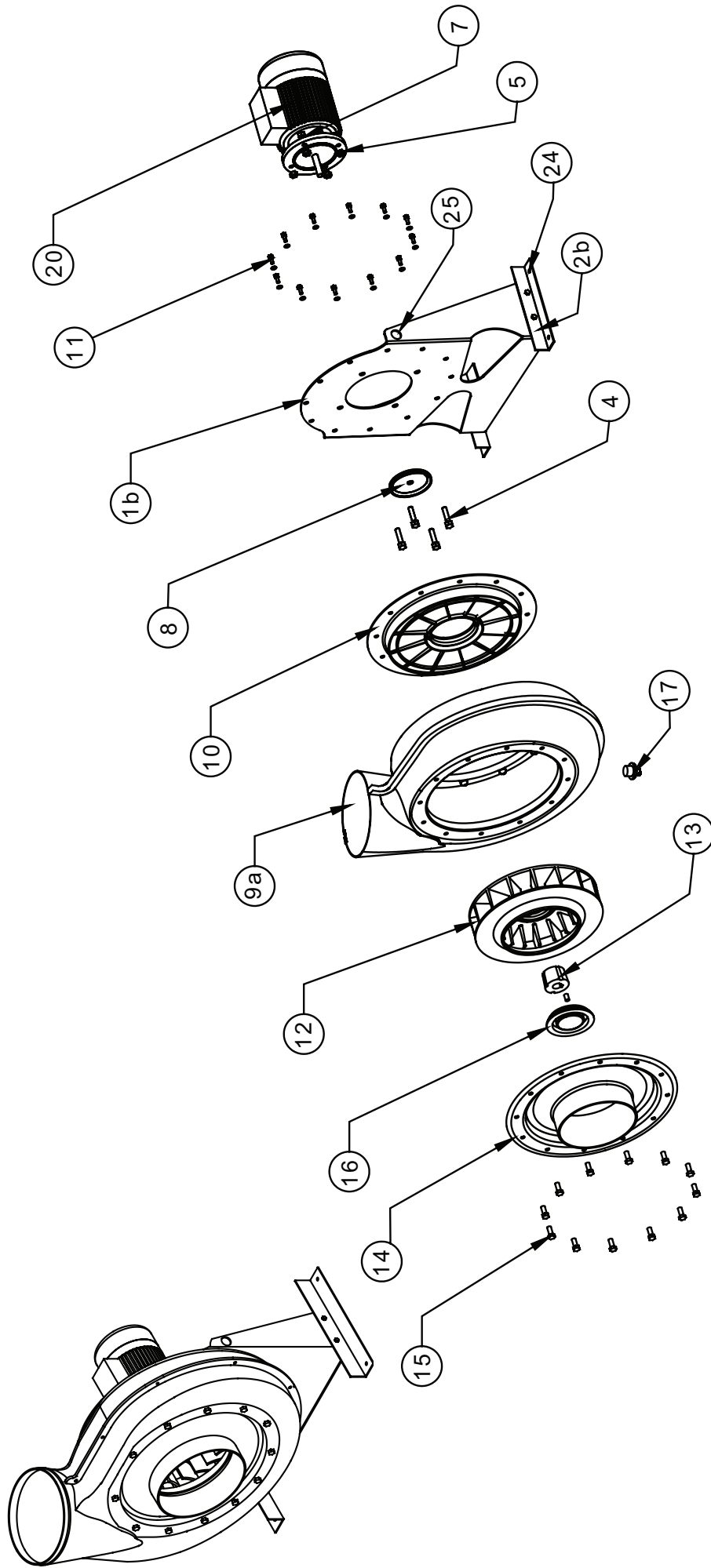

Part Nos	Beschreibung	Description	Part Nos	Beschreibung	Description
01-1b	Stahler Bock	Steel stand	01-12	Ventilatorauftrag	Fan impeller
01-2b	Grundrahmen für Direktantrieb/Fan	Base for direct drive	01-13	Taper-Buchse	Taper-Bushes
01-4	Sechskantschrauben	Hexagonal bolts	01-14	Gehäuseeinlaßabdeckung	Casing inlet cover
01-5	Sechskantmuttern	Hexagonal nuts	01-15	Schrauben	Bolts
01-7	Federringe und Muttern	Spring washers and nuts	01-16	Laufrollenabdeckung	Logo cap
01-8	Gummidichtung	Rubber gasket	01-17	Kondensatablaufverschluß	Drain plug
01-9a	Ventilatorgehäuse (PP typ)	Fan Casing (PP type)	01-20	Elektromotor	Electric motor
01-10	Gehäuserückseite	Casing back cover	01-24	Montageposition der Federschwingungstämpfer	Spring isolator mounting position
01-11	Unterlegscheiben und Muttern	Washers and bolts	01-25	Kranösen	Hoisting holes

Auf-und Einbau Assembly and mounting

CHEM 125 to 200 BD

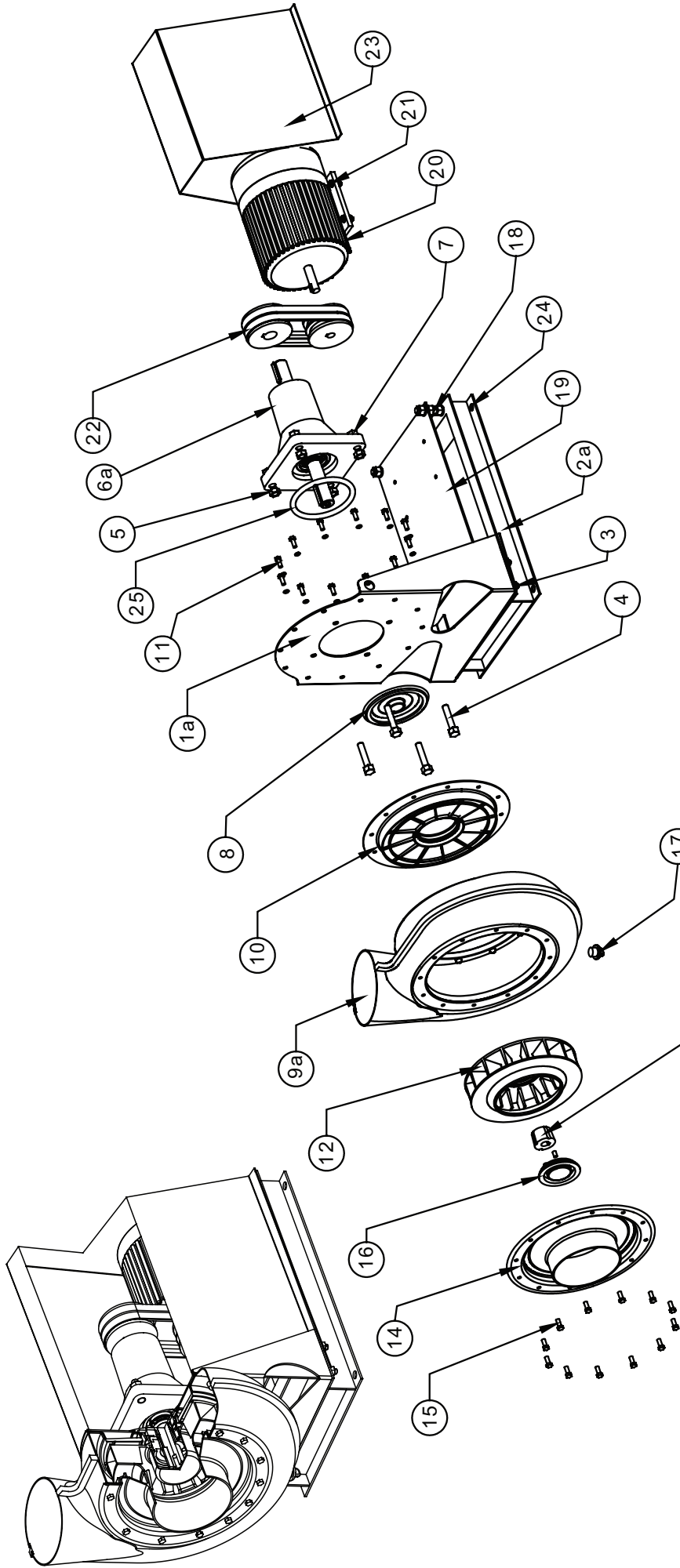

Part Nos	Beschreibung	Description	Part Nos	Beschreibung	Description
01-1a	Stahlener Bock	Steel stand	01-14	Gehäuseeinlaßabdeckung	Casing inlet cover
01-2a	Grundrahmen für Riementrieb	Base for belt drive	01-15	Schrauben	Bolts
01-3	Schrauben und Muttern	Bolts and nuts	01-16	Laufrollenabdeckung	Logo cap
01-4	Sechskantschrauben	Hexagonal bolts	01-17	Kondensatablaufverschluß	Drain plug
01-5	Sechskantmutter	Hexagonal nuts	01-18	Gewindestange, Unterlagscheiben und Muttern	Threaded rod, washers and nuts
01-6a	Flanschlager	Flange bearing	01-19	Motor montierungsplatte	Motor mounting plate
01-7	Federlinge und Muttern	Spring washers and nuts	01-20	Elektromotor	Electric motor
01-8	Gummidichtung	Rubber gasket	01-21	Sechskantschrauben, Unterlagscheiben und Muttern	Hexagonal bolts, washers and nuts
01-9a	Ventilatorgehäuse (PP type)	Fan casing (PP type)	01-22	Keil-Riemens und -Schleiben	Pulley and belts drive
01-10	Gehäuserückseite	Casing back cover	01-23	Riemenschutz	Belts guard
01-11	Unterlagscheiben und Muttern	Washers and bolts	01-24	Montageposition der Federungs-dämpfer	Spring isolator mounting position
01-12	Ventilatorlaufrad	Fan impeller	01-25	Stegelling	Seal ring
01-13	Taper-Buchse	Taper-Bushes			

Auf- und Einbau Assembly and mounting

CHEM 250 to 315 DD

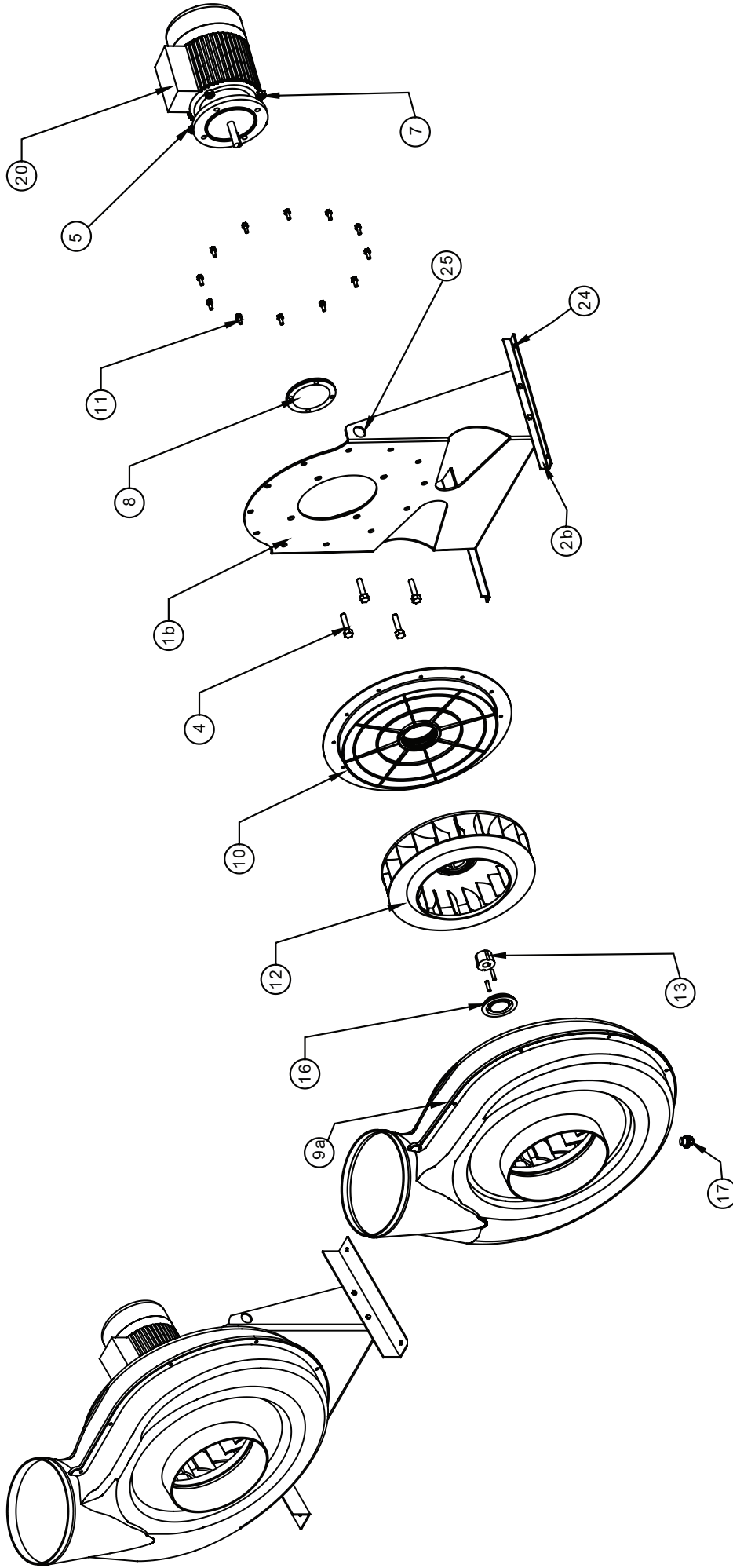

Part Nos	Beschreibung	Description	Part Nos	Beschreibung	Description
01-1b	Stählerner Bock	Steel stand	01-12	Ventilatoraufrad	Fan impeller
01-2b	Grundrahmen für Direkttrieb/Fan	Base for direct drive	01-13	Taper-Buchse	Taper-Bushes
01-4	Sechskantschrauben	Hexagonal bolts	01-16	Laufradwellenabdeckung	Logo cap
01-5	Sechskantmuttern	Hexagonal nuts	01-17	Kondensatablaufverschluß	Drain plug
01-7	Federringe und Muttern	Spring washers and nuts	01-20	Elektromotor	Electric motor
01-8	Gummidichtung	Rubber gasket	01-24	Montageposition der Feder-schwingungs-dämpfer	Spring isolator mounting position
01-9a	Ventilatorgehäuse (PP typ)	Fan casing (PP type)	01-25	Kranösen	Hoisting holes
01-10	Gehäuserückschleibe	Casing back cover			
01-11	Unterlegscheiben und Muttern	Washers and bolts			

Auf-und Einbau Assembly and mounting

CHEM 250-315 BD

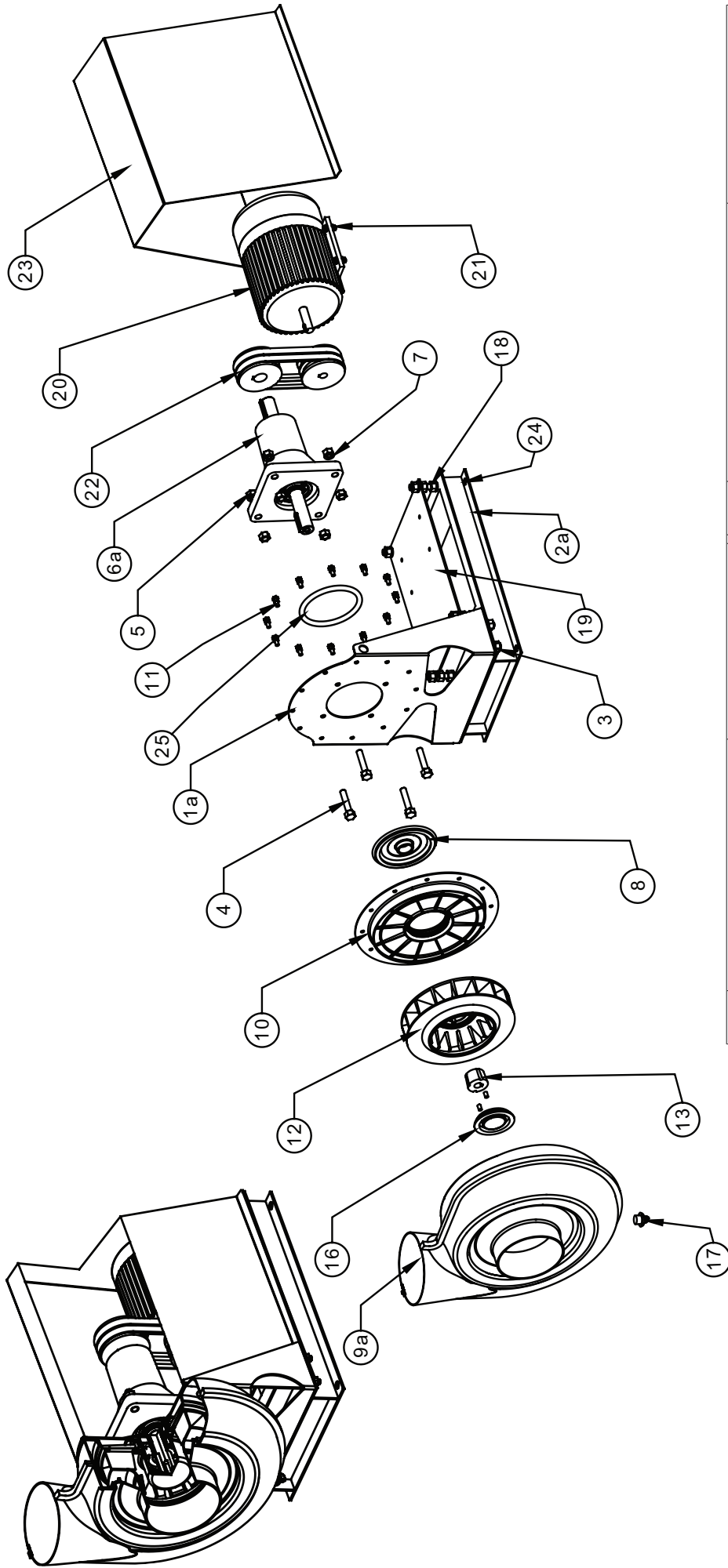

Part Nos	Beschreibung	Description	Part Nos	Beschreibung	Description
01-1a	Stahlener Bock	Steel stand	01-16	Laufrollenabdeckung	Logo cap
01-2a	Grundrahmen für Riementrieb	Base for belt drive	01-17	Kondensatablaufverschluß	Drain plug
01-3	Schrauben und Muttern	Bolts and nuts	01-18	Gewindestange, Unterlagscheiben und Muttern	Threaded rod, washers and nuts
01-4	Sechskantschrauben	Hexagonal bolts	01-19	Motor montageplatte	Motor mounting plate
01-5	Sechskantmutter	Hexagonal nuts	01-20	Elektromotor	Electric motor
01-6a	Flanschlager	Flange bearing	01-21	Sechskantschrauben, Unterlagscheiben und Muttern	Hexagonal bolts, washers and nuts
01-7	Federringe und Muttern	Spring washers and nuts	01-22	Keil-Riemlen und -Scheiben	Pulley and belts drive
01-8	Gummidichtung	Rubber gasket	01-23	Riemenschutz	Belts guard
01-9a	Ventilatorgehäuse (PP Typ)	Fan casing (PP type)	01-24	Montageposition der Federschwingungstämpfer	Spring isolator mounting position
01-10	Gehäuserückschiebe	Casing back cover	01-25	Siegelring	Seal ring
01-11	Unterlagscheiben und Muttern	Washers and bolts			
01-12	Ventilatorlaufrad	Fan impeller			
01-13	Taper-Buchse	Taper-Bushes			

Auf- und Einbau Assembly and mounting

CHEM 400 DD

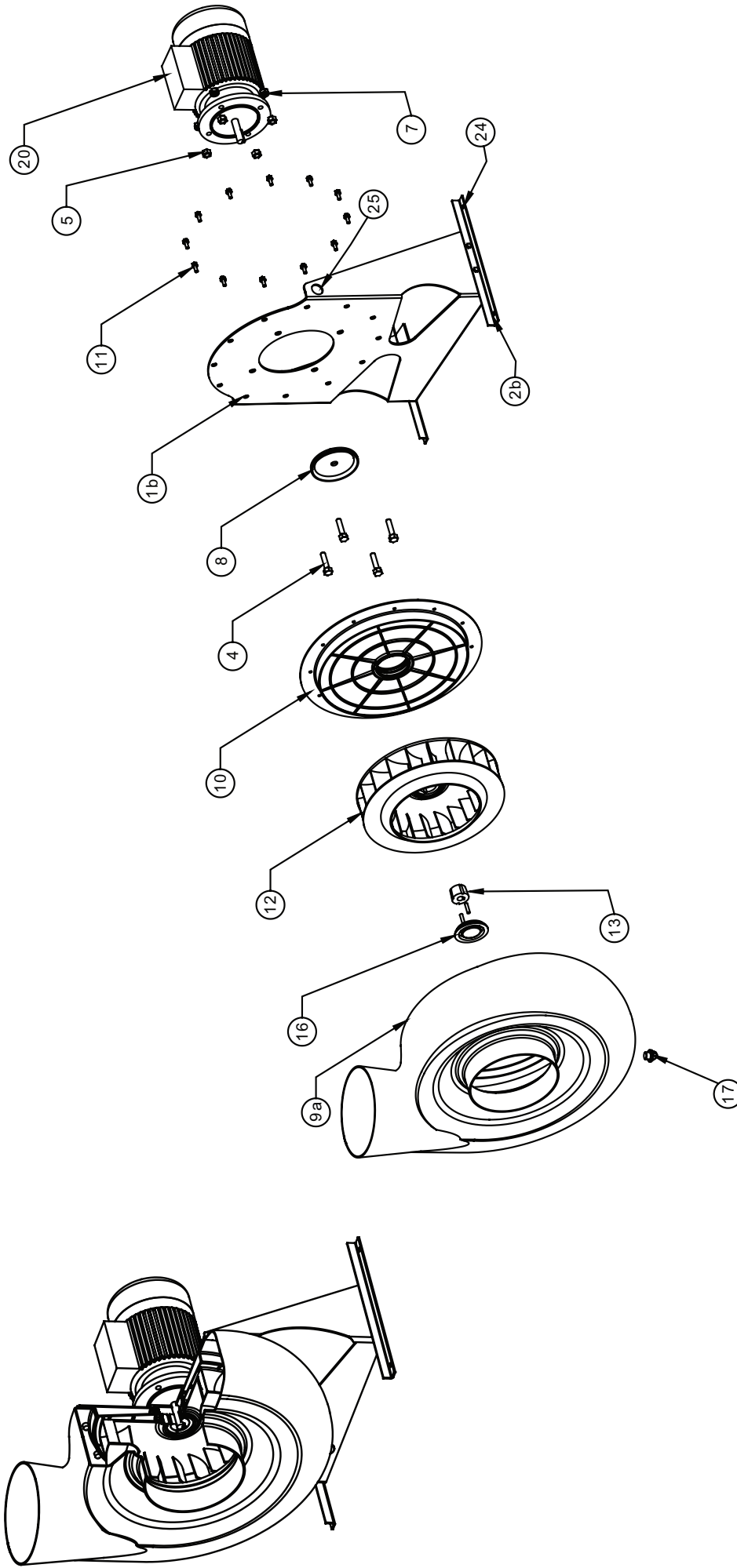

Part Nos	Beschreibung	Description	Part Nos	Beschreibung	Description
01-1b	Stahler Bock	Steel stand	01-12	Ventilatorlaufrad	Fan impeller
01-2b	Grundrahmen für DirektantriebFan	Base for direct drive	01-13	Taper-Buchse	Taper-bushes
01-4	Sechskantschrauben	Hexagonal bolts	01-16	Laufwellenabdeckung	Logo cap
01-5	Sechskantmuttern	Hexagonal nuts	01-17	Kondensatablauverschluss	Drain plug
01-7	Federlinge und Muttern	Spring washers and nuts	01-20	Elektromotor	Electric motor
01-8	Gummidichtung	Rubber gasket	01-24	Montageposition der Federschwingungsdämpfer	Spring isolator mounting position
01-9a	Ventilatorgehäuse (PP typ)	Fan casing (GRP type)	01-25	Kranösen	Hoisting holes
01-10	Gehäuserückscheibe	Casing back cover			
01-11	Unterlegscheiben und Müttern	Washers and bolts			

Auf-und Einbau Assembly and mounting

CHEM 400 BD

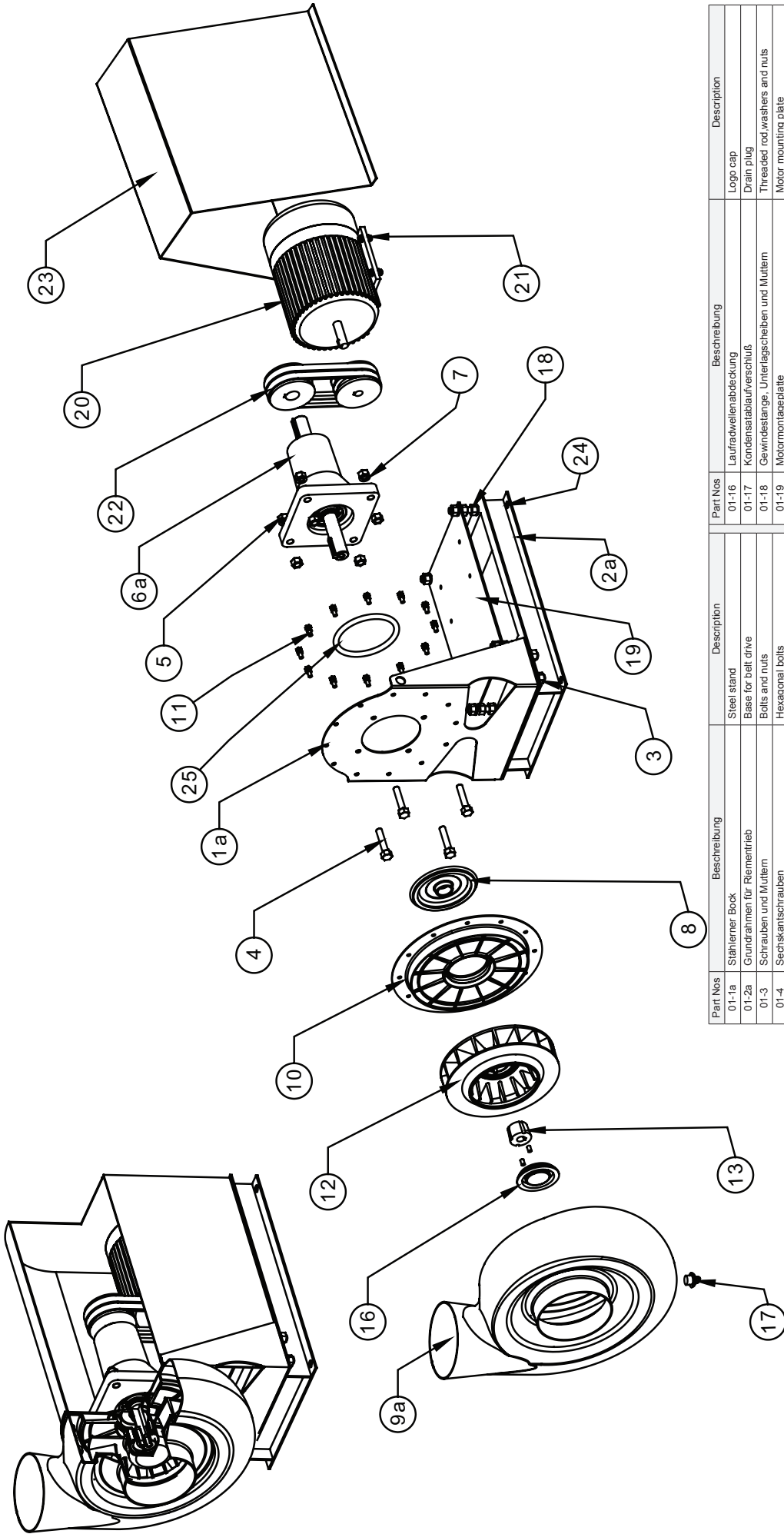

Part Nos	Beschreibung	Description	Part Nos	Beschreibung	Description
01-1a	Stahlerner Bock	Steel stand	01-16	Laufrollenabdeckung	Logo cap
01-2a	Grundrahmen für Riementrieb	Base for belt drive	01-17	Kondensatablaufverschluß	Drain plug
01-3	Schrauben und Muttern	Bolts and nuts	01-18	Gewindestange, Unterlagscheiben und Muttern	Threaded rod, washers and nuts
01-4	Sechskantschrauben	Hexagonal bolts	01-19	Motormontageplatte	Motor mounting plate
01-5	Sechskantmutter	Hexagonal nuts	01-20	Elektromotor	Electric motor
01-6a	Flanschlager	Flange bearing	01-21	Sechskantschrauben, Unterlagscheiben und Muttern	Hexagonal bolts, washers and nuts
01-7	Federhinge und Muttern	Spring washers and nuts	01-22	Kell-Riemlen und -Scheiben	Pulley and belts drive
01-8	Gummidichtung	Rubber gasket	01-23	Riemenschutz	Belts guard
01-9a	Ventilatorgehäuse (PP Typ)	Fan casing (PP type)	01-24	Montageposition der Federschwingungstämpfer	Spring isolator mounting position
01-10	Gehäuserückschiebe	Casing back cover	01-25	Siegeling	Seal ring
01-11	Unterlegscheiben und Muttern	Washers and bolts			
01-12	Ventilatoraufrad	Fan impeller			
01-13	Taper-Buchse	Taper-Bushes			

SPECIFICATION



Description	Specified	Offered						
CHEMCO Chemical Resistant Centrifugal Fan Model CHEM 75 - 315 DD (Direct Driven)	Polypropylene Plastic Fan							
Fan Location								
Volume m ³ /h External static pressure Pa Fan speed min ⁻¹ Brake-Input kW Motor-Output kW Full load Current A A-weighted Sound power level dB(A) Fan Weight Kg Standard Colour - Grey RAL 7032	PANTONE warm Grey 1C							
Type of Casing Precision plastic injection moulded. CHEM 125 - 200 are suitable for dual rotation at any position, Injection moulded back plate & inlet cover can be removed for changing of rotation and maintenance. Fan casing comes with round straight outlet suitable for direct connection to flexible connector. No metal parts are situated in the airflow to eliminate the risk of corrosion. Casings with drain outlets at lowest point. Can be rotated to suit different discharge positions. c/w back draft rubber seal between casing and drive shaft.	Polypropylene							
Type of Impeller Impellers are of Single Inlet Single Width (SISW) type. Precision plastic injection moulded with cast-in hub. The hubs are designed for use with taper-bushes to guarantee high reliability at high peripheral speeds. CHEM 90FC - 110FC are of forward curved blade.	Polypropylene Radial Tip Backward Curve							
Performance tested Fan rated in accordance with: Impeller is statically and dynamically balanced in two planes.	AMCA 210 / ISO 5801 G2.5 of VDI 2060							
Fan Base and Support Heavy gauge mild steel with maximum protection in the most adverse condition	Hot-dipped galvanised							
Type of Drive	Direct Driven							
Motor Drive Shaft Solid type ground and polished to give tight, accurate bearing fit.	DIN17210-C45 or AISI C-1045							
Motor Bearing Fitted with two standard anti-friction bearings with acid proof seal. L10 life	Grooved balls							
Electric motor Standard Flameproof Tropicalised Single Phase: Three Phase:	Yes/No Yes/No Yes/No 220~240 volts 50/60 Hz 380~415 volts 50/60 Hz							
Special Accessories Required Anti-vibration spring mounting Inlet sleeve with clamping bands Splinter protection cover	Yes/No Yes/No Yes/No							
Optional Requirement Temperature (°C) Casing material Impeller material Fan Base and Support	80 PA / PC / PVC / PVDF PA / PC / PVC / PVDF SS304 / SS316							
Flame Retardant Ultra Violet protection	Yes/No Yes/No							
Electrostatic Discharge Anti-static Static dissipative Conductive	Yes/No Yes/No Yes/No							
Maximum operating sound power level (dB re10 ⁻¹² W):								
Octave band mid frequency (Hz)	63	125	250	500	1K	2K	4K	8K
Specified								
Offered								

SPECIFICATION



Description	Specified	Offered
CHEMCO Chemical Resistant Centrifugal Fan Model CHEM 125 - 315BD (Belt Driven)	Polypropylene Plastic Fan	
Fan Location		
Volume External static pressure Fan speed Brake-Input Motor-Output Full load Current A-weighted Sound power level Fan Weight Standard Colour - Grey RAL 7032	m ³ /h Pa min ⁻¹ kW kW A dB(A) Kg PANTONE warm Grey 1C	
Type of Casing Precision plastic injection moulded. CHEM 125 - 200 are suitable for dual rotation at any position. Injection moulded back plate & inlet cover can be removed for changing of rotation and maintenance. Fan casing comes with round straight outlet suitable for direct connection to flexible connector. No metal parts are situated in the airflow to eliminate the risk of corrosion. Casings with drain outlets at lowest point. Can be rotated to suit different discharge positions. c/w back draft rubber seal between casing and drive shaft.	Polypropylene	
Type of Impeller Impellers are of Single Inlet Single Width (SISW) type. Precision plastic injection moulded with cast-in hub. The hubs are designed for use with taper-bushes to guarantee high reliability at high peripheral speeds	Polypropylene Radial Tip Backward Curve	
Performance tested Fan rated in accordance with: Impeller is statically and dynamically balanced in two planes.	AMCA 210 / ISO 5801 G2.5 of VDI 2060	
Fan Base and Support Heavy gauge mild steel with maximum protection in the most adverse condition	Hot-dipped galvanised	
Type of Drive	Belt Driven	
Drive Shaft Solid type ground and polished to give tight, accurate bearing fit. Bearing Belt driven flange mounted bearing housings type. Fitted with two standard anti-friction bearings with acid proof seal. L10 life	DIN17210-C45 or AISI C-1045 Aluminium cast type Grooved balls	
Fan Drive Fan and Motor Pulley drive come with taper bush type balanced to: Vee belts conform to:	ISO 4183-1980 ISO 4148	
Electric motor Standard Flameproof Tropicalised	Yes/No Yes/No Yes/No Single Phase: Three Phase:	
Special Accessories Required	Anti-vibration spring mounting Motor guard Motor slide rails Belt guard Inlet sleeve with clamping bands Splinter protection cover	Yes/No Yes/No Yes/No Yes/No Yes/No Yes/No
Optional Requirement	Temperature (°C) Casing material Impeller material Stainless steel shaft Fan Base and Support	80 PA / PC / PVC / PVDF PA / PC / PVC / PVDF SS304 / SS316 SS304 / SS316
	Flame Retardant Ultra Violet protection	Yes/No Yes/No
Electrostatic Discharge	Anti-static Static dissipative Conductive	Yes/No Yes/No Yes/No

Maximum operating sound power level (dB re 10 ⁻¹² W):								
Octave band mid frequency (Hz)	63	125	250	500	1K	2K	4K	8K
Specified								
Offered								

SPECIFICATION



Description	Specified	Offered						
CHEMCO Chemical Resistant Centrifugal Fan Model CHEM 400DD (Direct Driven)	GRP / PP Plastic Fan							
Fan Location								
Volume m ³ /h External static pressure Pa Fan speed min ⁻¹ Brake-Input kW Motor-Output kW Full load Current A A-weighted Sound power level dB(A) Fan Weight Kg Standard Colour - Volcano Grey	PANTONE 430							
Type of Casing Fibre Glass-Reinforced Plastic (GRP/FRP), Vinyl ester grade. Come with Injection moulded PP back plate can be removed for changing of rotation and maintenance. Straight outlet flange for easy duct connection. Max. Temp. 100°C. No metal parts are situated in the airflow to eliminate the risk of corrosion. Casings with drain outlets at lowest point. Casing can be rotated to suit different discharge positions. C/W back draft rubber seal between casing and drive shaft.	GRP							
Type of Impeller Impellers are of Single Inlet Single Width (SISW) type. Precision plastic injection moulded with cast-in hub. The hubs are designed for use with taper-bushes to guarantee high reliability at high peripheral speeds	Polypropylene Radial Tip Backward Curve							
Performance tested Fan rated in accordance with: Impeller is statically and dynamically balanced in two planes.	AMCA 210 / ISO 5801 G2.5 of VDI 2060							
Fan Base and Support Heavy gauge mild steel with maximum protection in the most adverse condition	Hot-dipped galvanised							
Type of Drive	Direct Driven							
Motor Drive Shaft Solid type ground and polished to give tight, accurate bearing fit.	DIN17210-C45 or AISI C-1045							
Motor Bearing Fitted with two standard anti-friction bearings with acid proof seal. L10 life	Grooved balls							
Electric motor Standard Flameproof Tropicalised Single Phase: Three Phase:	Yes/No Yes/No Yes/No 220~240 volts 50/60 Hz 380~415 volts 50/60 Hz							
Special Accessories Required Anti-vibration spring mounting Inlet sleeve with clamping bands Splinter protection cover	Yes/No Yes/No Yes/No							
Optional Requirement Temperature (°C) Casing material Impeller material Fan Base and Support	80 PA / PC / PVC / PVDF PA / PC / PVC / PVDF SS304 / SS316							
Flame Retardant Ultra Violet protection	Yes/No Yes/No							
Electrostatic Discharge Anti-static Static dissipative Conductive	Yes/No Yes/No Yes/No							
Maximum operating sound power level (dB re10 ⁻¹² W):								
Octave band mid frequency (Hz)	63	125	250	500	1K	2K	4K	8K
Specified								
Offered								

SPECIFICATION



Description		Specified	Offered					
CHEMCO Chemical Resistant Centrifugal Fan Model CHEM 400BD (Belt Driven)		GRP / PP Plastic Fan						
Fan Location								
Volume	m ³ /h							
External static pressure	Pa							
Fan speed	min ⁻¹							
Brake-Input	kW							
Motor-Output	kW							
Full load Current	A							
A-weighted Sound power level	dB(A)							
Fan Weight	Kg							
Standard Colour - Volcano Grey		PANTONE 430						
Type of Casing Fibre Glass-Reinforced Plastic (GRP/FRP), Vinyl ester grade. Come with Injection moulded PP back plate can be removed for changing of rotation and maintenance. Straight outlet flange for easy duct connection. Max. Temp. 100°C. No metal parts are situated in the airflow to eliminate the risk of corrosion. Casings with drain outlets at lowest point. Casing can be rotated to suit different discharge positions. $C_{1/2}$ back draft rubber seal between casing and drive shaft.		GRP						
Type of Impeller Impellers are of Single Inlet Single Width (SISW) type. Precision plastic injection moulded with cast-in hub. The hubs are designed for use with taper-bushes to guarantee high reliability at high peripheral speeds		Polypropylene Radial Tip Backward Curve						
Performance tested Fan rated in accordance with: Impeller is statically and dynamically balanced in two planes.		AMCA 210 / ISO 5801 G2.5 of VDI 2060						
Fan Base and Support Heavy gauge mild steel with maximum protection in the most adverse condition		Hot-dipped galvanised						
Type of Drive		Belt Driven						
Drive Shaft Solid type ground and polished to give tight, accurate bearing fit. Bearing Belt driven flange mounted bearing housings type. Fitted with two standard anti-friction bearings with acid proof seal. L10 life		DIN17210-C45 or AISI C-1045 Aluminium cast type Grooved balls						
Fan Drive Fan and Motor Pulley drive come with taper bush type balanced to: Vee belts conform to:		ISO 4183-1980 ISO 4148						
Electric motor Standard Flameproof Tropicalised Single Phase: Three Phase:		Yes/No Yes/No Yes/No 220~240 volts 50/60 Hz 380~415 volts 50/60 Hz						
Special Accessories Required Anti-vibration spring mounting Motor guard Motor slide rails Belt guard Inlet sleeve with clamping bands Splinter protection cover		Yes/No Yes/No Yes/No Yes/No Yes/No Yes/No						
Optional Requirement Temperature (°C) Casing material Impeller material Stainless steel shaft Fan Base and Support		80 PA / PC / PVC / PVDF PA / PC / PVC / PVDF SS304 / SS316 SS304 / SS316						
Flame Retardant Ultra Violet protection		Yes/No Yes/No						
Electrostatic Discharge Anti-static Static dissipative Conductive		Yes/No Yes/No Yes/No						
Maximum operating sound power level (dB re10 ⁻¹² W):								
Octave band mid frequency (Hz)	63	125	250	500	1K	2K	4K	8K
Specified								
Offered								

SPECIFICATION



Description		Specified	Offered					
CHEMCO Chemical Resistant Centrifugal Fan Model CHEM 450 - 710DD (Direct Driven)		GRP / PP Plastic Fan						
Fan Location								
Volume	m ³ /h							
External static pressure	Pa							
Fan speed	min ⁻¹							
Brake-Input	kW							
Motor-Output	kW							
Full load Current	A							
A-weighted Sound power level	dB(A)							
Fan Weight	Kg							
Standard Colour - Volcano Grey		PANTONE 430						
Type of Casing Fibre Glass-Reinforced Plastic (GRP/FRP), Vinyl ester grade. Come with Injection moulded PP back plate can be removed for changing of rotation and maintenance. Straight outlet flange for easy duct connection. Max. Temp. 100°C. No metal parts are situated in the airflow to eliminate the risk of corrosion. Casings with drain outlets at lowest point. Casing can be rotated to suit different		GRP						
Type of Impeller Impellers are of Single Inlet Single Width (SISW) type. Precision plastic injection moulded with cast-in hub. The hubs are designed for use with taper-bushes to guarantee high reliability at high peripheral speeds		Polypropylene Radial Tip Backward Curve						
Performance tested Fan rated in accordance with: Impeller is statically and dynamically balanced in two planes.		AMCA 210 / ISO 5801 G2.5 of VDI 2060						
Fan Base and Support Heavy gauge mild steel with maximum protection in the most adverse condition		Hot-dipped galvanised						
Type of Drive		Direct Driven						
Motor Drive Shaft Solid type ground and polished to give tight, accurate bearing fit.		DIN17210-C45 or AISI C-1045						
Motor Bearing Fitted with two standard anti-friction bearings with acid proof seal. L10 life		Grooved balls						
Electric motor Standard Flameproof Tropicalised Three Phase:		Yes/No Yes/No Yes/No 380~415 volts 50/60 Hz						
Special Accessories Required Inspection Door/Cover Anti-vibration spring mounting Inlet sleeve with clamping bands Splinter protection cover		Yes/No Yes/No Yes/No Yes/No						
Optional Requirement Temperature (°C) Casing material Impeller material Fan Base and Support		80 PA / PC / PVC / PVDF PA / PC / PVC / PVDF SS304 / SS316						
Flame Retardant Ultra Violet protection		Yes/No Yes/No						
Electrostatic Discharge Anti-static Static dissipative Conductive		Yes/No Yes/No Yes/No						
Maximum operating sound power level (dB re 10 ⁻¹² W):								
Octave band mid frequency (Hz)	63	125	250	500	1K	2K	4K	8K
Specified								
Offered								

SPECIFICATION



Description	Specified	Offered						
CHEMCO Chemical Resistant Centrifugal Fan Model CHEM 450 - 1250BD (Belt Driven)	GRP / PP Plastic Fan							
Fan Location								
Volume m ³ /h External static pressure Pa Fan speed min ⁻¹ Brake-Input kW Motor-Output kW Full load Current A A-weighted Sound power level dB(A) Fan Weight Kg Standard Colour - Volcano Grey	PANTONE 430							
Type of Casing Fibre Glass-Reinforced Plastic (GRP/FRP), Vinyl ester grade. Come with Injection moulded PP back plate can be removed for changing of rotation and maintenance. Straight outlet flange for easy duct connection. Max. Temp. 100°C. No metal parts are situated in the airflow to eliminate the risk of corrosion. Casings with drain outlets at lowest point. Casing can be rotated to suit different discharge positions. ^o / _w back draft rubber seal between casing and drive shaft.	GRP							
Type of Impeller Impellers are of Single Inlet Single Width (SISW) type. Precision plastic injection moulded with cast-in hub. The hubs are designed for use with taper-bushes to guarantee high reliability at high peripheral speeds	Polypropylene Radial Tip Backward Curve							
Performance tested Fan rated in accordance with: Impeller is statically and dynamically balanced in two planes.	AMCA 210 / ISO 5801 G2.5 of VDI 2060							
Fan Base and Support Heavy gauge mild steel with maximum protection in the most adverse condition	Hot-dipped galvanised							
Type of Drive	Belt Driven							
Drive Shaft Solid type ground and polished to give tight, accurate bearing fit. Bearing Belt driven flange mounted bearing housings type. Fitted with two standard anti-friction bearings with acid proof seal. L10 life	DIN17210-C45 or AISI C-1045 Aluminium cast type Grooved balls							
Fan Drive Fan and Motor Pulley drive come with taper bush type balanced to: Vee belts conform to:	ISO 4183-1980 ISO 4148							
Electric motor Standard Flameproof Tropicalised Three Phase:	Yes/No Yes/No Yes/No 380~415 volts 50/60 Hz							
Special Accessories Required Inspection Door/Cover Anti-vibration spring mounting Motor guard Motor slide rails Belt guard Inlet sleeve with clamping bands Splinter protection cover Manual / Semi / Automatic greasing system	Yes/No Yes/No Yes/No Yes/No Yes/No Yes/No Yes/No Yes/No							
Optional Requirement Temperature (°C) Casing material Impeller material Stainless steel shaft Fan Base and Support	80 PA / PC / PVC / PVDF PA / PC / PVC / PVDF SS304 / SS316 SS304 / SS316							
Flame Retardant Ultra Violet protection	Yes/No Yes/No							
Electrostatic Discharge Anti-static Static dissipative Conductive	Yes/No Yes/No Yes/No							
Maximum operating sound power level (dB re10 ⁻¹² W):								
Octave band mid frequency (Hz)	63	125	250	500	1K	2K	4K	8K
Specified								
Offered								

Wolter Sales Network

Inland

Ing. Günther Rößler
D-07619 Schkölen
Tel. (+49) 03 66 94 / 22 359
Fax (+49) 03 66 94 / 22 357
guenther.roessler@wolterfans.de

Mattias Industrievertretungen
D-16259 Bad Freienwalde
Tel. (+49)03344/301994
Fax (+49)03344/301996
thomas.mattias@wolterfans.de

Industrieservice Drexler
D-49080 Osnabrück
Tel. (+49) 0 541 / 20 04 88 3
Fax (+49) 0 541 / 20 04 88 4
wolfgang.drexler@wolterfans.de

Burkhardt Projekt GmbH
D-67583 Guntersblum
Tel. (+49) 0 62 49 / 82 01
Fax (+49) 0 62 49 / 88 58
info@bp-wolter.de

Friedrich Glock
D-97980 Bad Mergentheim
Tel. (+49) 0 79 31 / 37 44
Fax (+49) 0 79 31 / 28 58
friedrich.glock@wolterfans.de

Europe

Danmark:

Air-Con Danmark A/S
DK-8400 Ebeltoft
Tel. (+45)086/345111
Fax (+45)086/345810
bjb@air-con.dk

Hungary:

Air-Technik Légtechnikai Kft.
HU-2040 Budaörs
Tel. (+36)023/428533
Fax (+36)023/428544
bp.air-technik@troges.hu

Ireland:

Finheat Ltd.
IE-Dublin 12, Walkinstown
Tel. (+353)01/4564066
Fax (+353)01/4564071
sales@finheat.com

Lithuania:

JSC Saldos Prekyba
LT-78109 Siauliai
Tel. (+37)041/540212
Fax (+37)041/596176
prekyba@salda.lt

Netherlands:

AirFan B. V.
NL-7442 CX Nijverdal
Tel. (+31)054/8366366
Fax (+31)054/8365320
ventilatie@airfan.nl

Rucon B. V. Ventilatoren
NL-3840 AG Harderwijk
Tel. (+31)034/1411670
Fax (+31)034/1411690
verkoop@rucon.nl

Österreich:

Wolter Werksvertretung Österreich
A-4040 Linz
Tel. (+43) 07 32 / 75 77 07
Fax (+43)07 32 / 75 77 07 75
wolter.linz@aon.at

Wolter GmbH Maschinen-und Apparatebau KG

Am Wasen 11
D-76316 Malsch / Germany
Tel. +49 (0) 7204/9201-0
Fax +49 (0) 7204/9201-11
www.wolter.eu
info@wolter.eu

Poland:

Wentoprodukt
44-100 Gliwice
Tel. (+48)32 331-34-24
Fax (+48)32 729-76-53
biuro@wentoprodukt.pl

Portugal:

Safe Park Ventilação Industrial Lda.
P-2675-240 Odivelas
Tel. (+351) 21 93 / 75 265
Fax (+351) 21 93 / 86 061
safepark@netcabo.pt

Russia:

Euroclimat-Prof
RU-107082 Moskau
Tel. (+7) 4 95 / 97 57 530
Fax (+7) 4 95 / 97 57 530
gso@euroclimat.ru

Schweiz:

Anson AG Zürich
CH-8055 Zürich
Tel. (+41) 0 44 / 46 11 111
Fax (+41) 0 44 / 46 13 111
info@anson.ch

Ventra Technik AG
CH-8599 Salmsach
Tel. (+41) 0 71 / 46 11 447
Fax (+41) 0 71 / 46 11 448
ventra@bluewin.ch

Turkey:

Air Trade Centre Ltd Sti Türkiye,
TR-34418 Seyrantepe / Istanbul
Tel. (+90) 02 12 / 28 34 510
Fax (+90) 02 12 / 27 83 964
atc.turkey@airtradecentre.com

United Kingdom:

Wolter UK Ltd.
GB-B37 7UQ Solihull
Tel. (+44) 01 21 / 63 55 390
Fax (+44) 01 21 / 63 55 391
info@wolteruk.com

Middle East and North Africa

Egypt:

Tiba Engineering Industries Co.
Nasr City, Cairo
Tel. (+2) 02 / 40 22 866
Fax (+2) 02 / 40 44 771
tibaengineering@manz-group.com

Israel:

Lea Ventilation Industries Ltd.
IL-27113 Kiriyat-Bialik, Israel
Tel. (+972) 0 48 / 76 23 57
Fax (+972) 0 48 / 76 20 51
mail@lea.co.il

United Arab Emirates, Kuwait, Lebanon:

Wolter Ventilation LLC
Energy International
P.O. Box 3562 Sharjah, UAE
Tel. (+971) 06 / 53 43 477
Fax (+971) 06 / 53 43 756
energysh@emirates.net.ae

Asia

China Mainland:

Taizhou Wolter Ventilation Co. Ltd.
Hengjie, Luqiao District
Taizhou City, Zhejiang
Tel. (+86) 576 / 26 22 666 (26 52 888)
Fax (+86) 576 / 26 56 830

Hongkong:

Wolter Asia Ltd.
Hong Kong
Tel. (+852) 0 24 / 56 01 98
Fax (+852) 0 24 / 56 02 90
info@wolter.com.hk

India:

Wolter Ventilators India Pvt. Ltd.
867 D, Block-A, Sushant Lok, Phase-I,
Gurgaon - 122009 (Haryana)
Tel. +91 124 2577797, 4261001-3
sales@wolterindia.in

Indonesia:

PT. Agung Kipas Kastara.
ID-14440 Jakarta Indonesia
Tel. +62 (0) 21 / 6667 6925, 6667 6926
Fax +62 (0) 21 / 6667 6927
indowolter@cbn.net.id

Korea:

Kaceco-Wolter
14-1, Dang-dong, Gunpo-shi, Gyeonggi-do
Tel. +82 (0) 31 / 4773 104
Fax +82 (0) 31 / 4773 132
wolter@kaceco.com / info@kaceco.com

Malaysia:

Vibrantech (M) Sdn Bhd.
47200 Petaling Jaya Selangor, Malaysia
Tel. +603 (0) 7847 3500
Fax +603 (0) 7847 3380
sales@vibrantech-sb.com

Singapore:

Wolter Pte. Ltd.
SG-569738 Singapore
Tel. (+65) 0 63 / 52 95 48
Fax (+65) 0 63 / 52 95 47
info@wolterfans.com.sg

Sri Lanka:

Sirocco Air Technologies (Pvt) Ltd.
28/12, Gemunu Mawatha, Kotuwegoda,
Rajagiriya, Sri Lanka
Tel. +94 11 7 392 010
Fax +94 11 7 392 015
suren@sairt.com

Taiwan:

Waxlink International Co., Ltd.
8F No. 218 Roosevelt Rd., Sec. 6
Taipei, Taiwan
Tel. (+886) 02 / 89 32 11 96
Fax (+886) 02 / 89 32 11 97
waxlink.tech@msa.hinet.net

Thailand:

Wolter Ventilation Co., Ltd.
Thamai Kratumban Samutsakorn 74110
Thailand
Tel. +66 (0) 3486 6555
Fax +66 (0) 3486 6599
natiphan@wolterfan.com

Australia

The Sydney Fan Company.
NSW 2147, Sydney, Australia
Tel. +61 (0) 2 / 9624 4000
Fax +61 (0) 2 / 9624 4100
sales@thesydneyfancompany.com





Reference: **R04.4**, V2014/April, Printed in April, 2014